

Description

- suitable for solenoids with 24VDC and a current of 0.95A max
- Europacard format 100 x 160 mm
- 32-pin male connectors type F or C according to DIN 41612 (DIN 41617 on request)
- current stabilised output
- adjustable dither to control the valve hysteresis
- limitation of min- and max-current, adjustable for each channel
- 4 adjustable ramp functions
- acceleration starting from minimum-current (I_{min})
- 4 internal preset value potentiometers, activated with on board relays

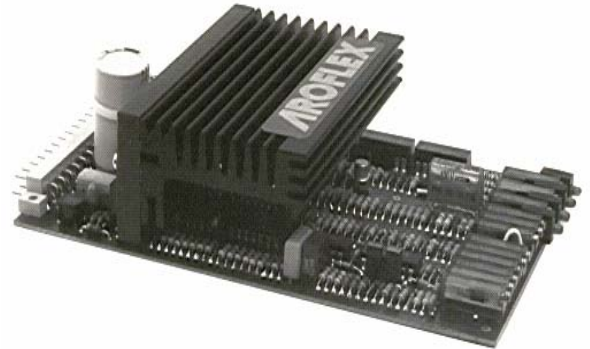

The current stabilising Europacard EX-5001 controls the DC-solenoids of analogue valves (proportional valves) supplying a constant current, independent of coil temperature and resistance.

The current controller is combined with a ramp generator to obtain an adjustable and smooth acceleration and deceleration of any load.

Acceleration and deceleration can be individually adjusted for both outputs.

Technical data

Power supply		26 V AC \pm 10 %
Power		40 VA
Min-current (I_{min})	adjustable	0 - 500 mA
Max-current (I_{max})	adjustable	50 - 950 mA
Output voltage		24 V (Open circuit 40 V)
Ramp rate	adjustable	1 : 60
Load resistance		= 16 Ohm
Dither: frequency		ca. 125 Hz
pulse width		30 %
amplitude	adjustable	0 - 150 mA pp
Ambient temperature		0 - 45° C
Weight		approx. 400 g

The EX-Europacards cannot control two outputs at the same time. Only one input should be on at any one time. When both inputs are active the first switched on of the two signals is selected and the other input is in effect cancelled. The resistance of the remote current control potentiometers should be 10 kΩ and the total load-resistance must not be lower than 1 kΩ (maximum 6 external potentiometers with 4 potentiometers internal).

Ramp function

EX-Europacards provide a smooth adjustable, change in output current, on sudden changes in input signal. A channel blocking circuit is incorporated to ensure that the down ramp is completed for one output before the up ramp on the other output can start.

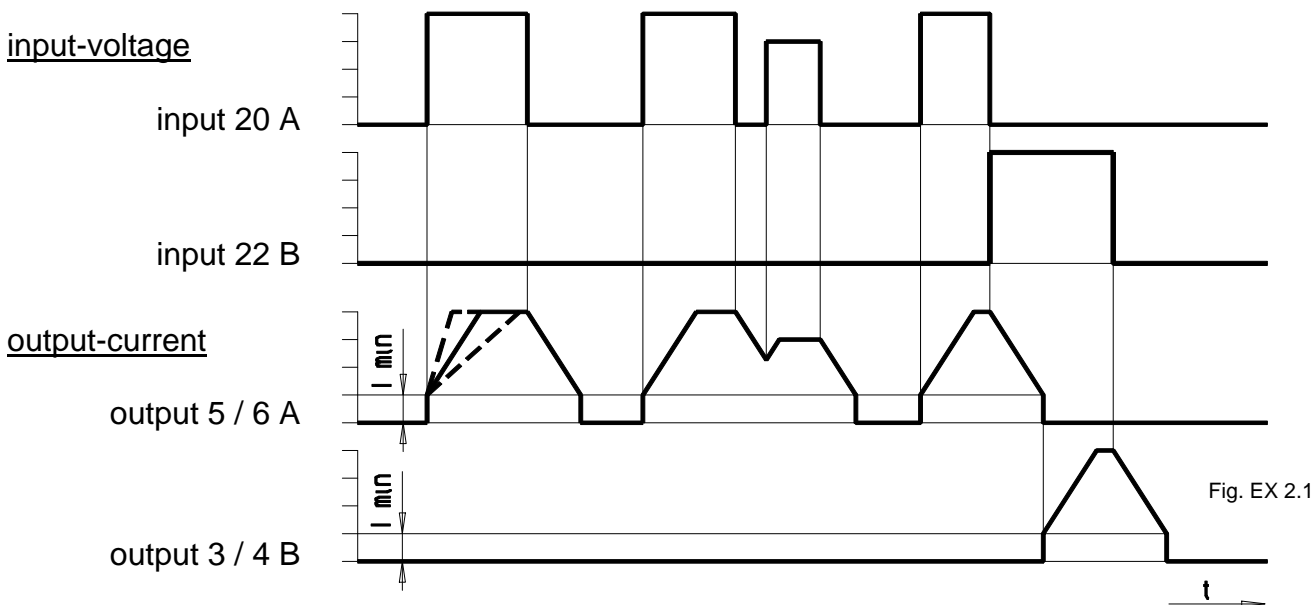

Input from external source

The input from external source has to be potential free to the supply voltage. The input voltage has to be within the range as shown in the diagram below.

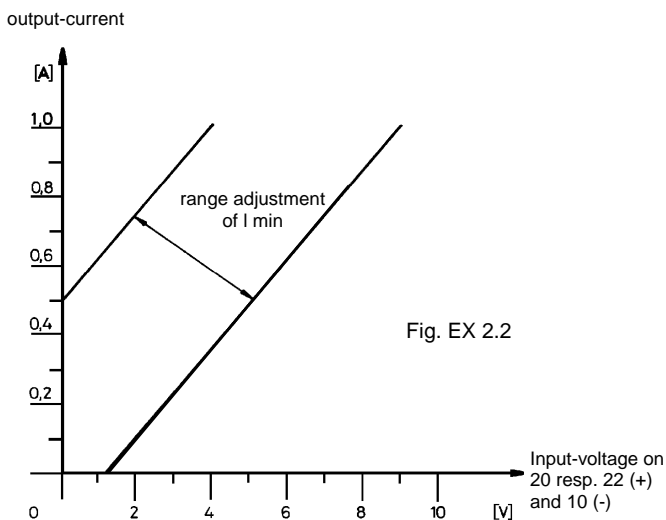

Input voltage at pin 20 resp. pin 22 and pin 10 (I_{min}) max. 12 VDC

Bi-polar voltage control max. +/- 10 V DC (option)

DIN 41612		DIN 41617	Designation
C	F		
2a	2z	1	power supply 26 V ~ +/- 10 %
2c	2b	2	
4a	4z	3	solenoid B
4c	4b	4	
6a	6z	5	solenoid A
6c	6b	6	
8a	8z	7	
8c	8b	8	remote potentiometer max
10a	10z	9	0 V relay resp. ground
10c	10b	10	remote potentiometer min
12a	12z	11	relay control, internal potentiometer A1
12c	12b	12	relay control, internal potentiometer A2
14a	14z	13	relay control, internal potentiometer B1
14c	14b	14	relay control, internal potentiometer B2
16a	16z	15	potentiometer ramp, deceleration A
16c	16b	16	2. connection potentiometer 15/17 (0V)
18a	18z	17	potentiometer ramp, acceleration A
18c	18b	18	connection for external potentiometer
20a	20z	19	
20c	20b	20	input A
22a	22z	21	
22c	22b	22	input B
24a	24z	23	
24c	24b	24	* input voltage bi-polar +/-
26a	26z	25	* ramp potentiometer A/B
26c	26b	26	* ramp potentiometer A/B
28a	28z	27	
28c	28b	28	* input voltage common, to input 24
30a	30z	29	potentiometer ramp, deceleration B
30c	30b	30	2. connection potentiometer 29/30 (0V)
32a	32z	31	potentiometer ramp, acceleration B
32c	32b		*special models

Connection diagram

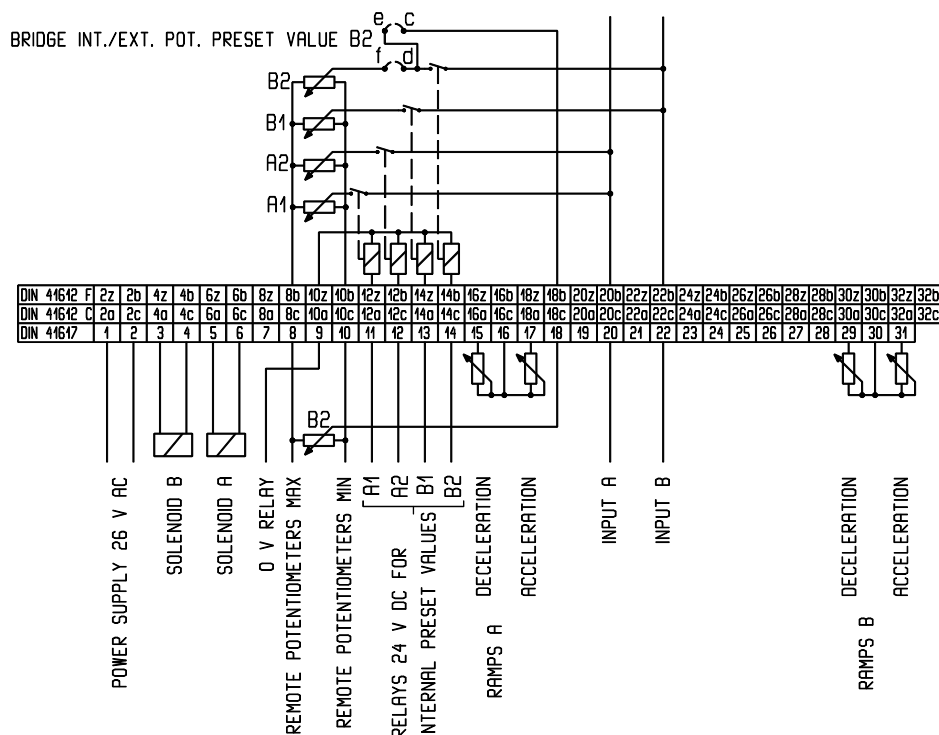

Block diagram

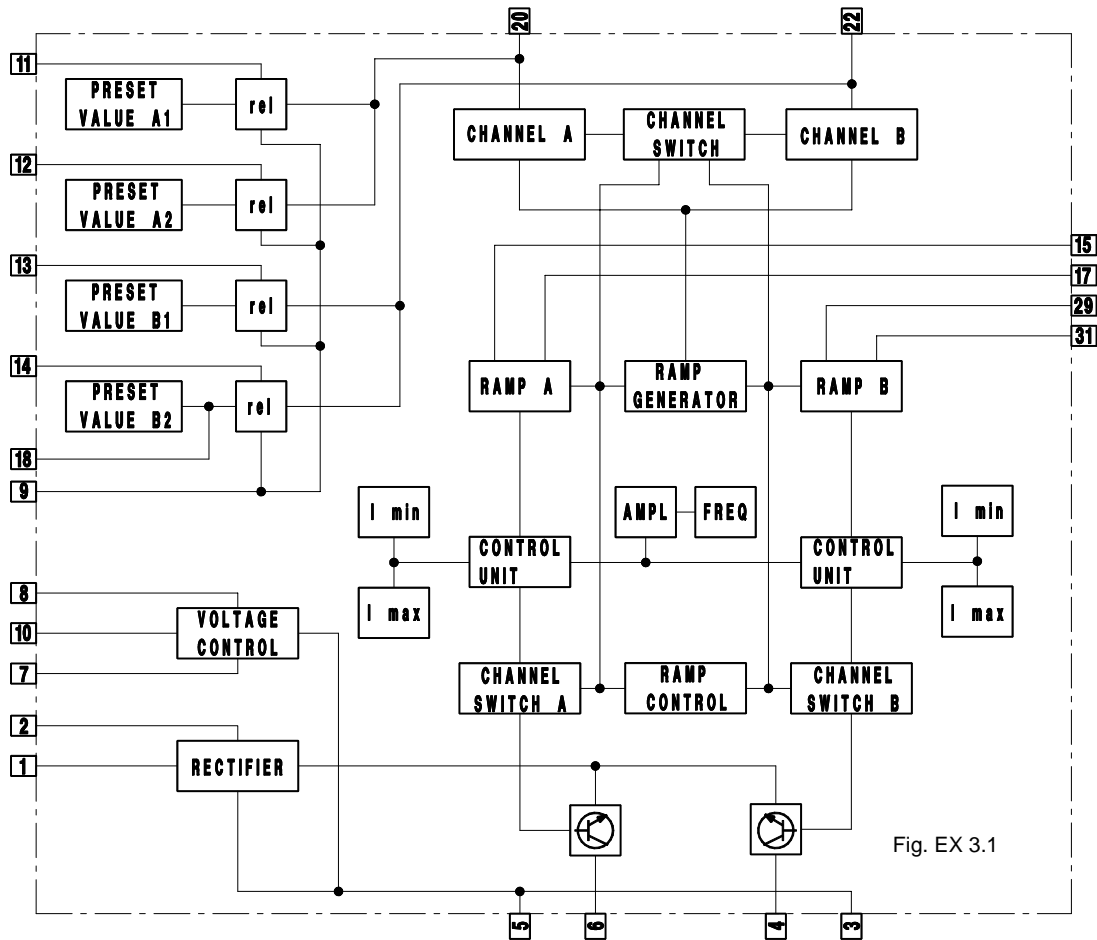

Unit dimensions

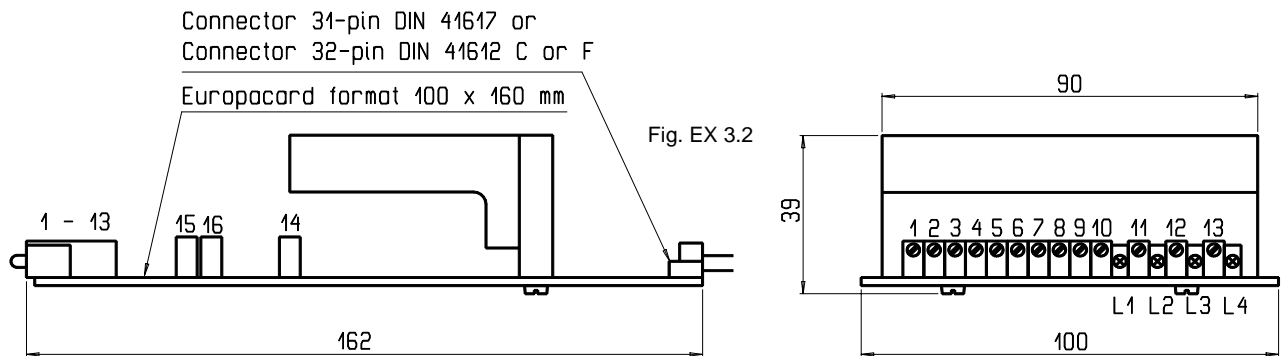

Potentiometers

- | | |
|---|---|
| 1 Max.-current A | 11 Preset value internal potentiometer channel A2 |
| 2 Max.-current B | 12 Preset value internal potentiometer channel B1 |
| 3 Ramp channel B deceleration | 13 Preset value internal potentiometer channel B2 |
| 4 Ramp channel A acceleration | 14 Amplitude |
| 5 Ramp channel A deceleration | 15 * Balance |
| 6 Ramp channel B acceleration | 16 * Gain bi-polar input |
| 7 * common ramp functions | L1 Control-LED relay preset value 1 |
| 8 Min.-current channel A | L2 Control-LED relay preset value 2 |
| 9 Min.-current channel B | L3 Control-LED relay preset value 3 |
| 10 Preset value internal potentiometer channel A1 | L4 Control-LED relay preset value 4 |

* special model

Jumper for preset value B2

With the type EX 5001-T1-BR it is possible to change the preset value B2 from the internal to the external potentiometer by using a jumper.

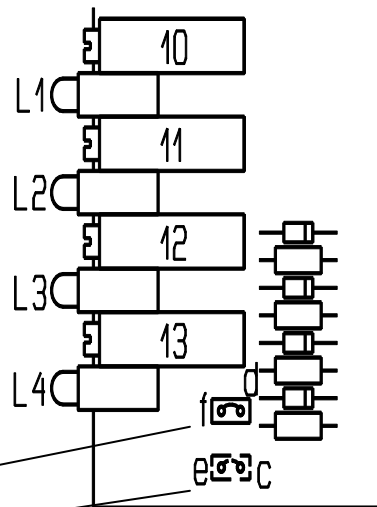

Internal potentiometer = jumper on d-f
 External potentiometer = jumper on c-e

Ordering code

EX-5001-T1-BR - * * - S

Standard model

Power supply 26 V ~
 Ramp internal separately adjustable
 Ramp time 80 ms - 6 sec, at 500 mA change of current
 Connector 31-pin DIN 41617

Special model

Current control +/- 20 mA
 Ramp external separately adjustable
 Ramp with one potentiometer for all functions internal
 Ramp with one potentiometer for all functions external
 Special short ramp time 2,5 - 750 ms
 Special long ramp time 3 sec. - 100 sec.
 Bi-polar voltage control +/- 10 V

Connector 32-pin DIN 41612 type C (a+c provided)

Connector 32-pin DIN 41612 type F (z+b provided)

Special model (e.g. 24 VDC power supply = S24VDC)

