

Zwischenplattenventile, NG 6 / NG 10

Multi-Stack Valves, Size 3 / Size 5

Valvole modulari, grandezza 3 / grandezza 5



SAUER  BIBUS

Zwischenplattenventil, NG 6

Multi-stack valve, size 3

Valvola modulare, grandezza 3

Inhaltsverzeichnis · Contents · Indice

Sinnbild Symbol Simbolo	Baureihe Series Grandezza	Seite Page Pagina	Sinnbild Symbol Simbolo	Baureihe Series Grandezza	Seite Page Pagina	Sinnbild Symbol Simbolo	Baureihe Series Grandezza	Seite Page Pagina	
Druckbegrenzungsventil Pressure relief valve Valvola di massima pressione			Drosselventil Throttle valve Strozzatore			Rückschlagventil, hydraulisch entsperbar Pilot operated check valve Ritegno pilotato			
	J - MR - 02P - * - 60	5		J - MT - 02P - 60	17		J - MC - 02W - 50	25	
	J - MR - 02A - * - 60			J - MT - 02T - 60			J - MC - 02AB - * - 50		
	J - MR - 02B - * - 60		Drosselventil mit Umgehungs-Rückschlagventil Throttle valve with free flow return check valve Strozzatore con ritegno direzionale			Rückschlagventil, hydr. entsperbar, mit Vorentlastung Pilot operated check valve with decompression Ritegno pilotato con decompressione			
Schockventil, direkt gesteuert Direct operating crossover relief valve Valvola di max. diretta doppia incrociata			Drosselventil mit Umgehungs-Rückschlagventil Throttle valve with free flow return check valve Strozzatore con ritegno direzionale			Rückschlagventil, hydr. entsperbar, mit Vorentlastung Pilot operated check valve with decompression Ritegno pilotato con decompressione			
	J - MB - 02W - * - 60	7		J - MT - 02AI - 60	19		J - MP - 02A - * - 60	27	
Druckregelventil, direkt gesteuert Direct pressure control valve valvola regolatrice di pressione ad azione diretta				J - MT - 02BI - 60			J - MP - 02B - * - 60		
				J - MT - 02WI - 60			J - MP - 02W - * - 60		
				J - MT - 02A - 60		Zusatzplatten Subplates Piastrre aggiuntive			
	J - MG - 02P - * - 60	9		J - MT - 02B - 60		21		J - BD - 02PA - 60	31
	J - MG - 02A - * - 60			J - MT - 02W - 60				J - BD - 02PT - 60	
	J - MG - 02B - * - 60			J - MT - 02W - 60			J - BE - 02 - 60		
Druckregelventil, vorgesteuert Pilot pressure control valve Valvola regolatrice di pressione pilotata			Drosselventil mit Rückschlagventil Throttle valve with check valve Strozzatore con valvola di non ritorno			Sammelanschlußplatten Manifold plates Piastrre multiple			
	J - MGB - 02P - 03- 50	11		J - MTC - 02P - 50	23		J - BF - 02 - 60		
	J - MGB - 02B - 03- 50			J - MC - 02A - * - 60			J - BH - 02 - 60		
Druckfolgeventil, direkt gesteuert Direct operating sequence valve Valvola di sequenza a pilotaggio diretto			Rückschlagventil Check valve Valvola di non ritorno			Sammelanschlußplatten Manifold plates Piastrre multiple			
	J - MQ - 02P - ** - 50	13		J - MC - 02B - * - 60	25		J - BG - 02AB - 60		
Vorspannventil mit Umgehungs-Rückschlagventil Counter balance valve with free flow return check valve Valvola di bilanciamento con ritegno				J - MC - 02P - * - 60			J - BG - 02PT - 60		
				J - MC - 02T - * - 60			J - BS - 02 - 60		
	J - MQC - 02A - 2- 60	15	Rückschlagventil Check valve Valvola di non ritorno			Zubehör Accessories Accessori			
	J - MQC - 02B - 2- 60			J - MC - 02PA - * - 60	25	Befestigungsschrauben Fixing bolts Viti di fissaggio			
				J - MC - 02PB - * - 60		33			

Zwischenplattenventil, NG 10

Multi-stack valve, size 5

Valvola modulare, grandezza 5

Inhaltsverzeichnis · Contents · Indice

Sinnbild Symbol Simbolo	Baureihe Series Grandezza	Seite Page Pagina	Sinnbild Symbol Simbolo	Baureihe Series Grandezza	Seite Page Pagina
Druckbegrenzungsventil, vorgesteuert Pilot operating pressure relief valve Valvola di massima pressione pilotata			Rückschlagventil Check valve Ritegno		
	J - MR - 03P - * - 40	34		J - MC - 03P - *5 - 40	46
Druckregelventil, vorgesteuert Pilot pressure control valve Valvola regolatrice di pressione pilotata				J - MC - 03T - *5 - 40	
	J - MG - 03P - * - 40	36	Rückschlagventil, hydr. entsperrbar, mit Vorentlastung Pilot operated check valve with decompression Valvola di non ritorno sbloccabile idraulic. con decompress.		
	J - MG - 03B - * - 40			J - MP - 03A - *0 - 40	48
Druckfolgeventil, direkt gesteuert Direct operating sequence valve valvola di sequenza ad azione diretta				J - MP - 03B - *0 - 40	
	J - MQ - 03P - 2A - 40	38		J - MP - 03W - *0 - 40	
	J - MQ - 03P - 2C - 40		Zusatzplatten Subplates Piastrre aggiuntire		
	J - MQ - 03P - 2E - 40			J - BE - 03 - 40	50
Vorspannventil mit Umgehungs-Rückschlagventil Counter balance valve with free flow return check valve Valvola di bilanciamento con ritegno				J - BS - 03 - 40	
	J - MQ - 03B - 1A - 40	40	Reihenanschlußplatten Manifold plates Piastrre multiple		
	J - MQ - 03B - 1C - 40			51	
	J - MQ - 03B - 1E - 40		J - BT - *03 - 40		
Drosselventil Throttle valve Strozzatore			Zubehör Accessories Accessori		
	J - MT - 03P - 40	42	Befestigungsschrauben Fixing bolts Viti di fissaggio		
Drosselventil mit Umgehungs-Rückschlagventil Throttle valve with free flow return check valve Strozzatore con ritegno direzionale			Gewindebolzen Stud bolts Bulloni		
	J - MT - 03W - 40	44	52		
	J - MT - 03WI - 40				

Zwischenplattenventil, NG 6 und 10

Multi-stack valve, size 3 and 5

Valvola modulare, grandezze 3 e 5

Kenngößen · Operating data · Dati caratteristici

Allgemeine Kenngößen · General operating data · Dati caratteristici generali		
Befestigungsart Type of attachment Fissaggio	-	Anschlußlochbild nach DIN 24340 Form A, ISO 4401 und CETOP R 35 H Connection bore diagram acc. to DIN 24340 form A, ISO 4401 and CETOP R 35 H Disposizione dei fori di attacco secondo DIN 24340 foglio A, ISO 4401 e CETOP R 35 H
Anschlußgröße Size Dimensione di attacco	-	NG 6 und 10 CETOP 3 and · e 5
Einbaulage Mounting position Posizione di montaggio	-	beliebig any qualsiasi
Druckeinstellbereich Pressure adjustment range Campo di regolazione pressione	bar	siehe Ventilbeschreibung see valve description vedi descrizione valvola
Gewicht Weight Peso	kg	siehe Ventilbeschreibung see valve description vedi descrizione valvola
Hydraulische Kenngößen · Hydraulic operating data · Dati caratteristici idraulici		
Max. Betriebsdruck Max. operating pressure Press. di funzionamento	bar	siehe Ventilbeschreibung see valve description vedi descrizione valvola
Max. Rücklaufdruck (Anschluß T) Max. return line pressure (port T) Max. contropressione (Attacco T)	bar	Empfehlung Recommendation Raccomandati } ≤ 5
Druckflüssigkeit und Viskositätsbereich Hydraulic fluid and viscosity range Fluido idraulico e campo di viscosità	-	auf Mineralölbasis nach DIN 51524 und DIN 51525 empfohlene Viskositätsklassen ISO VG 32, 46, 68 Viskositätsbereich 15 ... 400 mm ² /s on mineral oil base DIN 51524 and DIN 51525 recommended viscosity classes ISO VG 32, 46, 68 viscosity range 15 ... 400 mm ² /s oli a base minerale secondo DIN 51524 e DIN 51525 gamma di viscosità consigliata ISO VG 32, 46, 68 campo di viscosità 15 ... 400 mm ² /s
Druckmitteltemperatur Hydraulic fluid temperature Gamma di temperatura del fluido idr.	C°	- 15 ... +70
Reinheitsgrad der Druckflüssigkeit Fluid cleanliness Grado di pulizia del fluido	-	18/15 nach ISO 4406 oder 9 nach NAS 1638 und besser, insbesondere bei hohen Belastungen und Lebensdauernanforderungen 18/15 to ISO 4406 or 9 to NAS 1638 or better, especially at high loads and high life expectancy requirements 18/15 secondo ISO 4406 oppure 9 secondo NAS 1638 o migliori in particolare con carichi gravosi o se viene richiesta una durata elevata
Max. Durchfluß Max. flow rate Portata max.	L/min	siehe Ventilbeschreibung see valve description vedi descrizione valvola
Empfohlene Filterfeinheit Filtration requirements Grado di filtraggio	µm	≤ 25 absolut / absolute / assoluti

Tabelle / Table / Tabella 1

Zwischenplattenventil, NG 6
Multi-stack valve, size 3
Valvola modulare, grandezza 3

Baureihe J-MR
Series J-MR
Serie J-MR

Druckbegrenzungsventil · Pressure relief valve · Valvola limitatrice di pressione



Bild / Fig. 1

Sinnbilder · Symbols · Simbolo

J - MR - 02P - * - 60

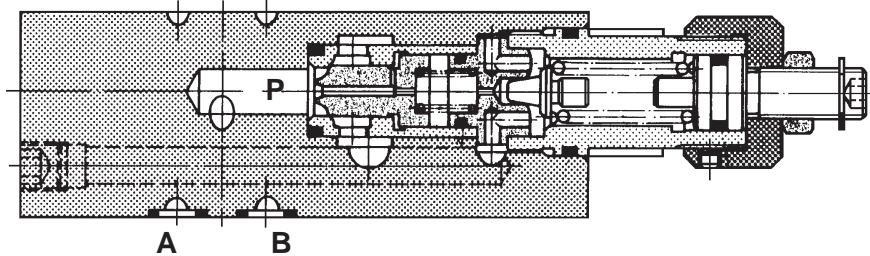

Bild / Fig. 2

J - MR - 02A - * - 60

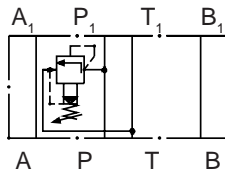

Bild / Fig. 3

J - MR - 02B - * - 60

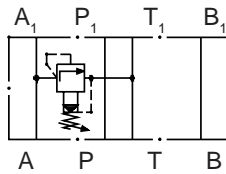

Bild / Fig. 4

Kenngößen · Operating data · Dati caratteristici

Druckeinstellbereich Pressure adjustment range Campo di regolazione press.	siehe Typenschlüssel see model code vedi chiave di ordinazione
Max. Betriebsdruck Max. operating pressure Press. di funzionamento max.	350 bar
Max. Durchfluß Max. flow rate Portata max.	40 L/min

Gewicht Weight Peso	1,5 kg 1,7 kg mit Handrad with handwheel con volantino
---------------------------	---

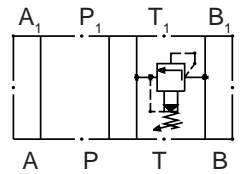
Typenschlüssel · Model code · Chiave di ordinazione

J - M R - 0 2 * - * - 6 0 - T

Baureihe
Series = J-MR
Serie

Baugröße NG 6 = 02
Size CETOP 3
Grandezza

Druckbegrenzung
Pressure relief
Limitazione di pressione
P -> T = P
A -> T = A
B -> T = B

Verstellung
mit Werkzeug = ohne Angabe
mit Handrad = T
Adjustment
with tool = without instruction
with handwheel = T
Registrazione
con utensile = senza specifica
con volantino = T

Ausführungskennzeichen (Stand bei Druck)
Design Number (release on print date)
N° del tipo (alla presente edizione)
= 60

Druckeinstellbereich
Pressure adjustment range
Campo di regolazione pressione
70 bar = 1
35 bar - 160 bar = 2
35 bar - 250 bar = 3
70 bar - 350 bar = 4

Zwischenplattenventil, NG 6
Multi-stack valve, size 3
Valvola modulare, grandezza 3

Baureihe J-MR
Series J-MR
Serie J-MR

Kennlinien · Characteristics · Curve caratteristiche

ermittelt bei $v = 32 \text{ mm}^2/\text{s}$ · determ. at $v = 32 \text{ mm}^2/\text{s}$ · rilevate con $v = 32 \text{ mm}^2/\text{s}$

J - MR - 02A - * - 60
J - MR - 02B - * - 60

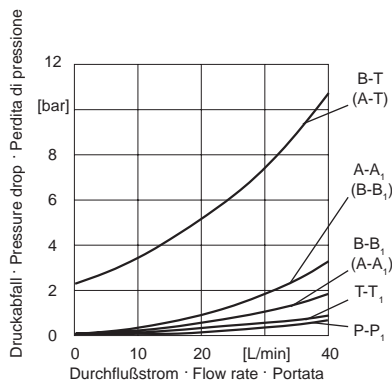

J - MR - 02P - * - 60



Bild / Fig. 5

Bild / Fig. 6

Bild / Fig. 7

— Öffnungsdruck
 Cracking pressure
 Press. d'apertura

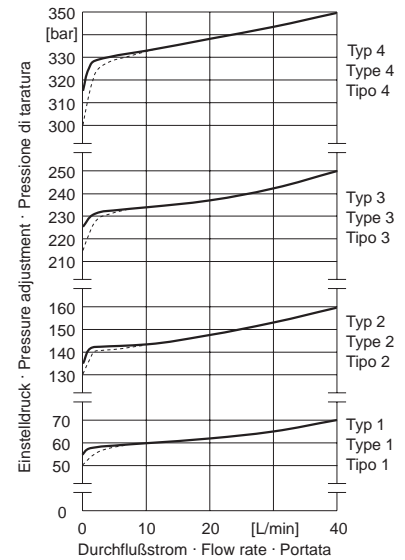
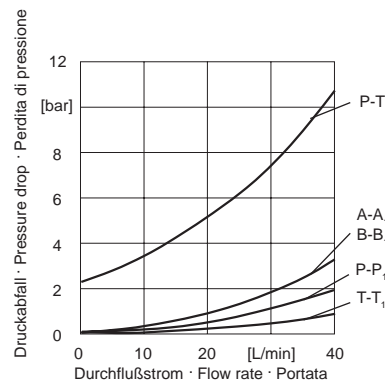
- - - Schließdruck
 Reseat pressure
 Press. di chiusura

Geräteabmessungen · Installation dimensions · Dimensioni



Bild / Fig. 8

Zwischenplattenventil, NG 6
Multi-stack valve, size 3
Valvola modulare, grandezza 3

Baureihe J-MB
Series J-MB
Serie J-MB

Schockventil, direkt gesteuert · Direct operating crossover relief valve ·
Valvola di max. diretta doppia incrociata

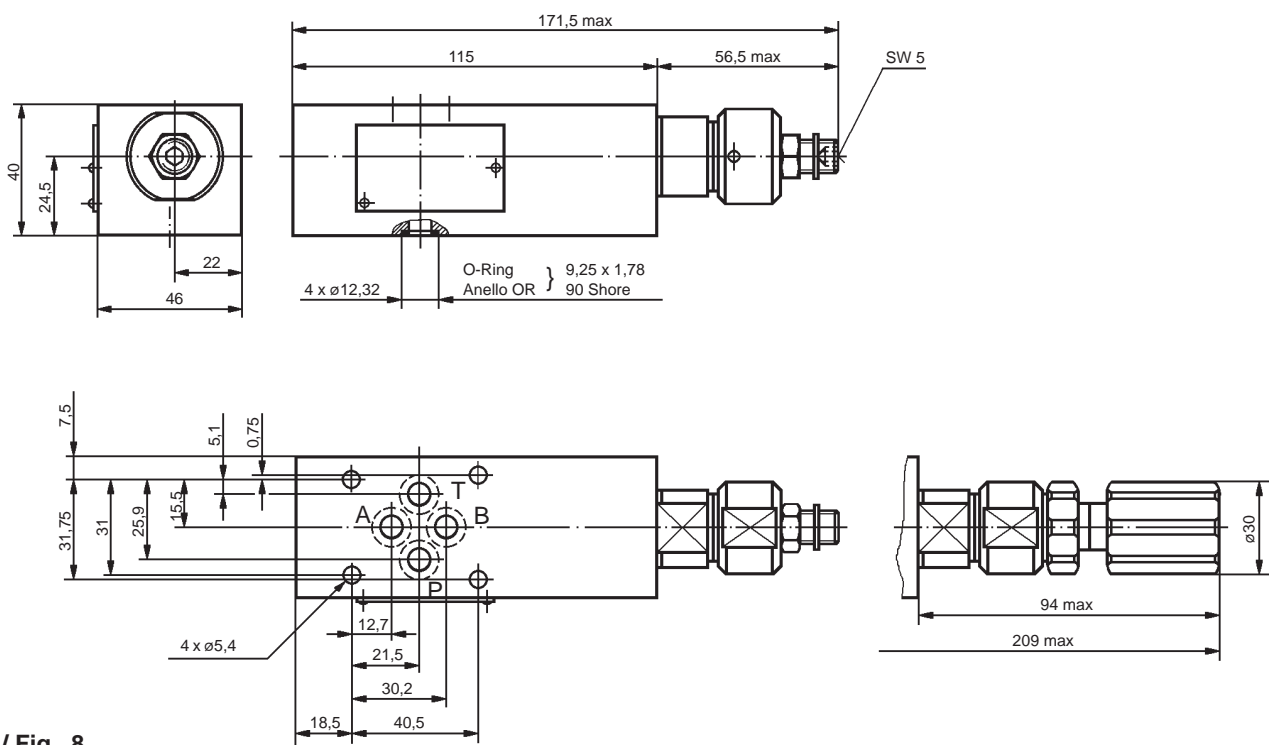

Bild / Fig. 1

Sinnbild · Symbol · Simbolo

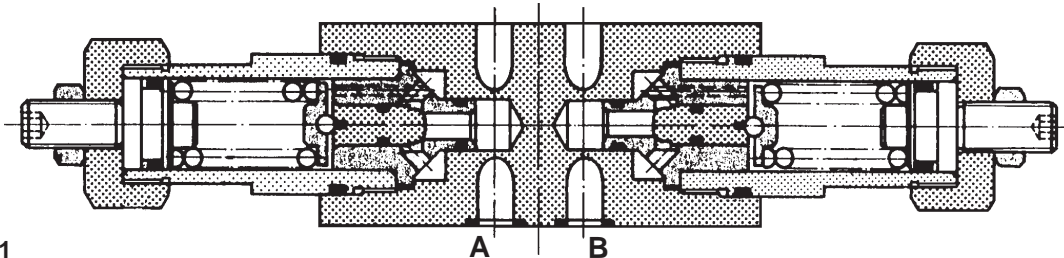

Bild / Fig. 2

Kenngößen · Operating data · Dati caratteristici

Druckeinstellbereich Pressure adjustment range Campo di regolazione press.	siehe Typenschlüssel see model code vedi chiave di ordinazione	Gewicht Weight Peso	1,5 kg
Max. Betriebsdruck Max. operating pressure Press. di funzionamento max.	350 bar		
Max. Durchfluß Max. flow rate Portata max.	20 L/min		

Typenschlüssel · Model code · Chiave di ordinazione

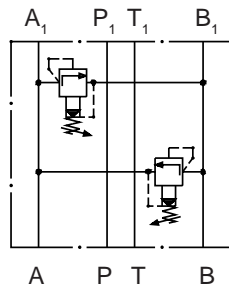
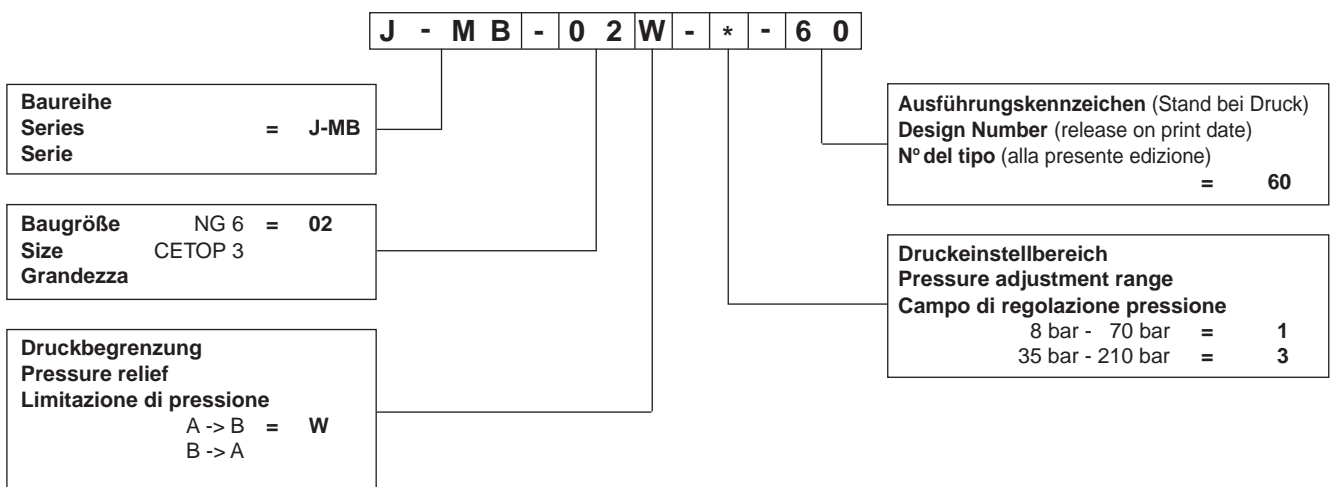

Zwischenplattenventil, NG 6
Multi-stack valve, size 3
Valvola modulare, grandezza 3

Baureihe J-MB
Series J-MB
Serie J-MB

Kennlinien · Characteristics · Curve caratteristiche

ermittelt bei $v = 32 \text{ mm}^2/\text{s}$ · determ. at $v = 32 \text{ mm}^2/\text{s}$ · rilevate con $v = 32 \text{ mm}^2/\text{s}$



Bild / Fig. 3



Bild / Fig. 4

Geräteabmessungen · Installation dimensions · Dimensioni

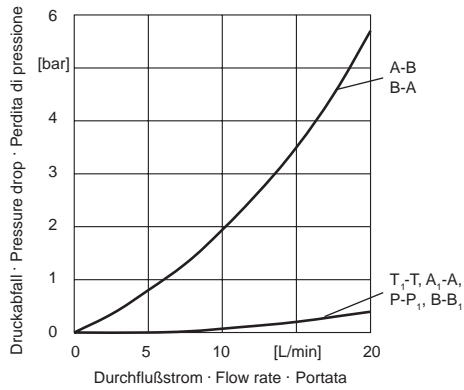

Bild / Fig. 5

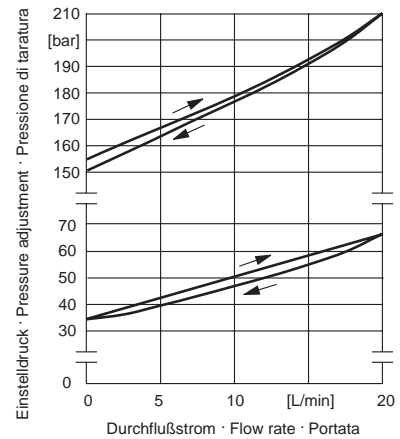
Zwischenplattenventil, NG 6
Multi-stack valve, size 3
Valvola modulare, grandezza 3

Baureihe J-MG
Series J-MG
Serie J-MG

Druckregelventil, direkt gesteuert · Direct pressure control valve
Valvola regolatrice di pressione ad azione diretta

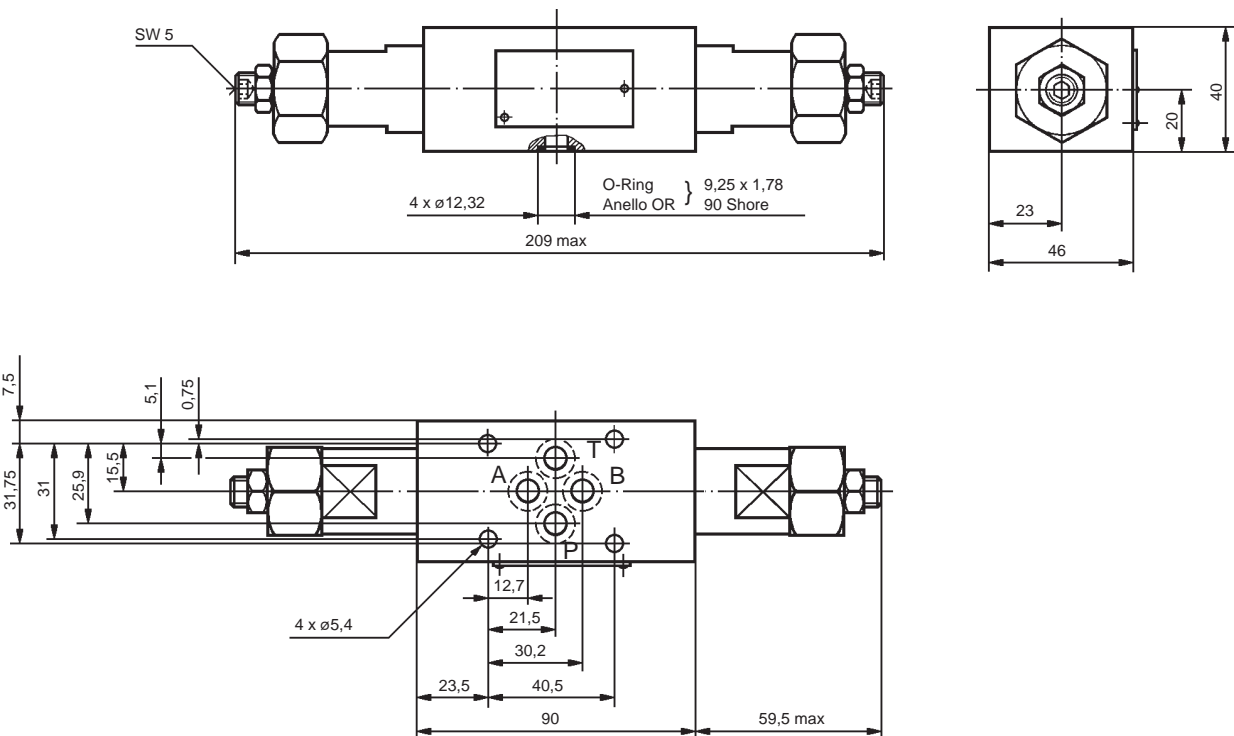

Bild / Fig. 1

Sinnbild · Symbol · Simbolo

J - MG - 02P - * - 60

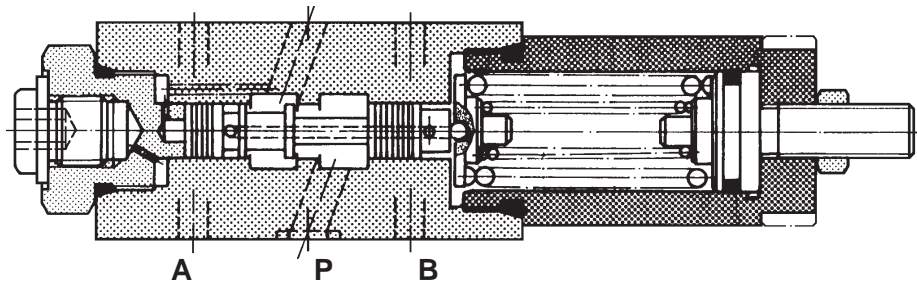

Bild / Fig. 2

J - MG - 02A - * - 60

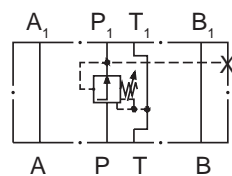

Bild / Fig. 3

J - MG - 02B - * - 60

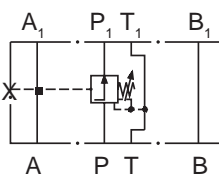

Bild / Fig. 4

Kenngößen · Operating data · Dati caratteristici

Druckeinstellbereich Pressure adjustment range Campo di regolazione press.	siehe Typenschlüssel see model code vedi chiave di ordinazione	Gewicht Weight Peso	1,3 kg 1,5 kg mit Handrad with handwheel con volantino
Max. Betriebsdruck Max. operating pressure Press. di funzionamento max.	350 bar	Um eine gute Druckminderung zu erzielen, sollte die Differenz zwischen Primär- und Sekundärdruck größer als 10 bar sein. To get good reducing effects, pressure difference between primary and secondary pressure should be maintained higher than 10 bar. Per ottenere una buona regolazione, la differenza tra la pressione primaria e quella secondaria dovrebbe essere di almeno 10 bar.	
Max. Durchfluß Max. flow rate Portata max.	40 L/min		

Typenschlüssel · Model code · Chiave di ordinazione

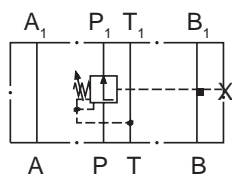
J - M G - 0 2 * - * - 6 0 - T

Baureihe Series Serie = J-MG	Verstellung mit Werkzeug = ohne Angabe mit Handrad = T Adjustment with tool = without instruction with handwheel = T Registrazione con utensile = senza specifica con volantino = T
Baugröße NG 6 = 02 Size CETOP 3 Grandezza	Ausführungskennzeichen (Stand bei Druck) Design Number (release on print date) N° del tipo (alla presente edizione) = 60
Druckminderung Pressure reducing Riduzione pressione in P = P in A = A in B = B	Druckeinstellbereich Pressure adjustment range Campo di regolazione pressione 3 bar - 35 bar = 03 7 bar - 70 bar = 1 35 bar - 160 bar = 2 35 bar - 250 bar = 3*

* Sonderausführung · Special Type ·
Costruzione speciale

Zwischenplattenventil, NG 6
Multi-stack valve, size 3
Valvola modulare, grandezza 3

Baureihe J-MGB
Series J-MGB
Serie J-MGB

Druckregelventil, vorgesteuert · Pilot pressure control valve ·
Valvola regolatrice di pressione pilotato



Bild / Fig. 1

Sinnbild · Symbol · Simbolo

J - MGB - 02P - 03 - 50

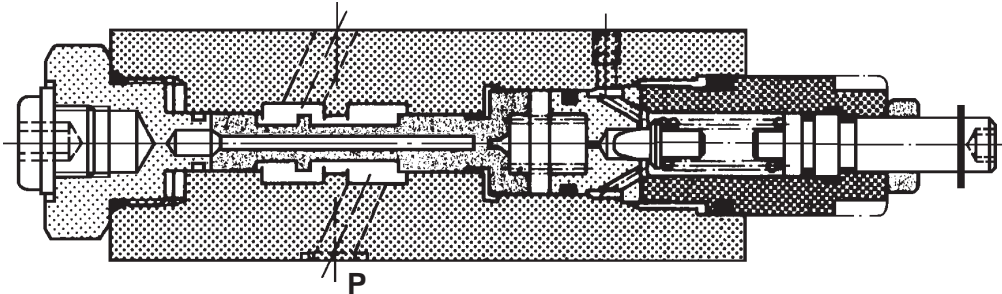

Bild / Fig. 2

J - MGB - 02B - 03 - 50

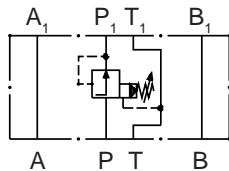

Bild / Fig. 3

Kenngößen · Operating data · Dati caratteristici

Druckeinstellbereich Pressure adjustment range Campo di regolazione press.	siehe Typenschlüssel see model code vedi chiave di ordinazione	Gewicht Weight Peso	1,3 kg 1,5 kg mit Handrad with handwheel con volante
Max. Betriebsdruck Max. operating pressure Press. di funzionamento max.	250 bar	Um eine gute Druckminderung zu erzielen, sollte die Differenz zwischen Primär- und Sekundärdruck größer als 4 bar sein. To get good reducing effects, pressure difference between primary- and secondary pressure should be maintained higher than 4 bar. Per ottenere una buona regolazione, la differenza tra la pressione primaria e quella secondaria dovrebbe essere di almeno 4 bar.	
Max. Durchfluß Max. flow rate Portata max.	20 L/min		

Typenschlüssel · Model code · Chiave di ordinazione

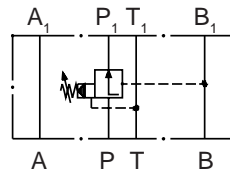
J - M G B - 0 2 * - 0 3 - 5 0 - T

Baureihe Series Serie	= J-MGB	Verstellung mit Werkzeug mit Handrad Adjustment with tool with handwheel Registrazione con utensile con volante	= ohne Angabe = T = without instruction = T = senza specifica = T
Baugröße Size Grandezza	NG 6 = 02 CETOP 3	Ausführungskennzeichen (Stand bei Druck) Design Number (release on print date) N° del tipo (alla presente edizione)	= 50
Druckminderung Pressure reducing Riduzione pressione	in P = P in B = B	Druckeinstellbereich Pressure adjustment range Campo di regolazione pressione	1,5 bar - 35 bar = 03

Zwischenplattenventil, NG 6
Multi-stack valve, size 3
Valvola modulare, grandezza 3

Baureihe J-MGB
Series J-MGB
Serie J-MGB

Kennlinien · Characteristics · Curve caratteristiche

ermittelt bei $v = 32 \text{ mm}^2/\text{s}$ · determ. at $v = 32 \text{ mm}^2/\text{s}$ · rilevate con $v = 32 \text{ mm}^2/\text{s}$



Bild / Fig. 4

Bild / Fig. 5

Bild / Fig. 6

Geräteabmessungen · Installation dimensions · Dimensioni

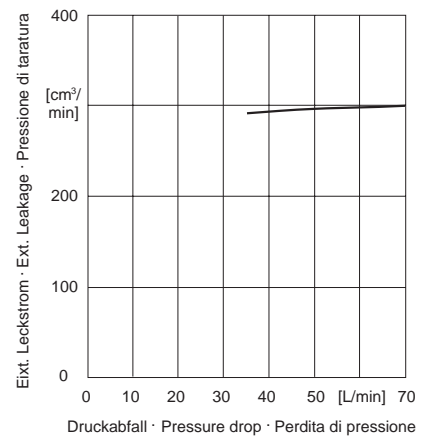
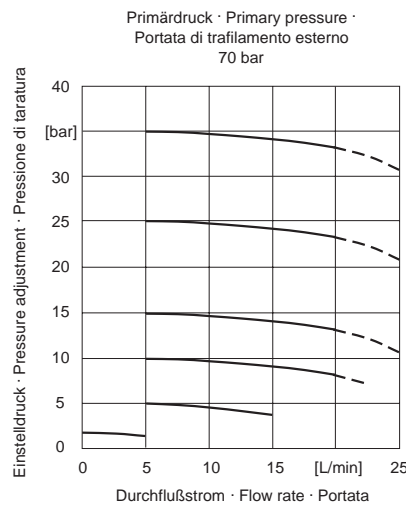
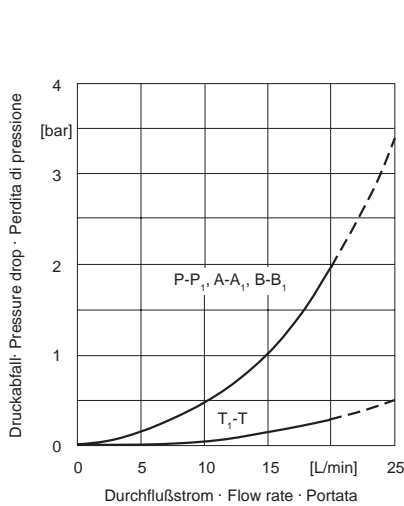

Bild / Fig. 7

Zwischenplattenventil, NG 6
Multi-stack valve, size 3
Valvola modulare, grandezza 3

Baureihe J-MQ
Series J-MQ
Serie J-MQ

Druckfolgeventil, direkt gesteuert · Direct operating sequence valve ·
Valvola di sequenza a pilotaggio diretto

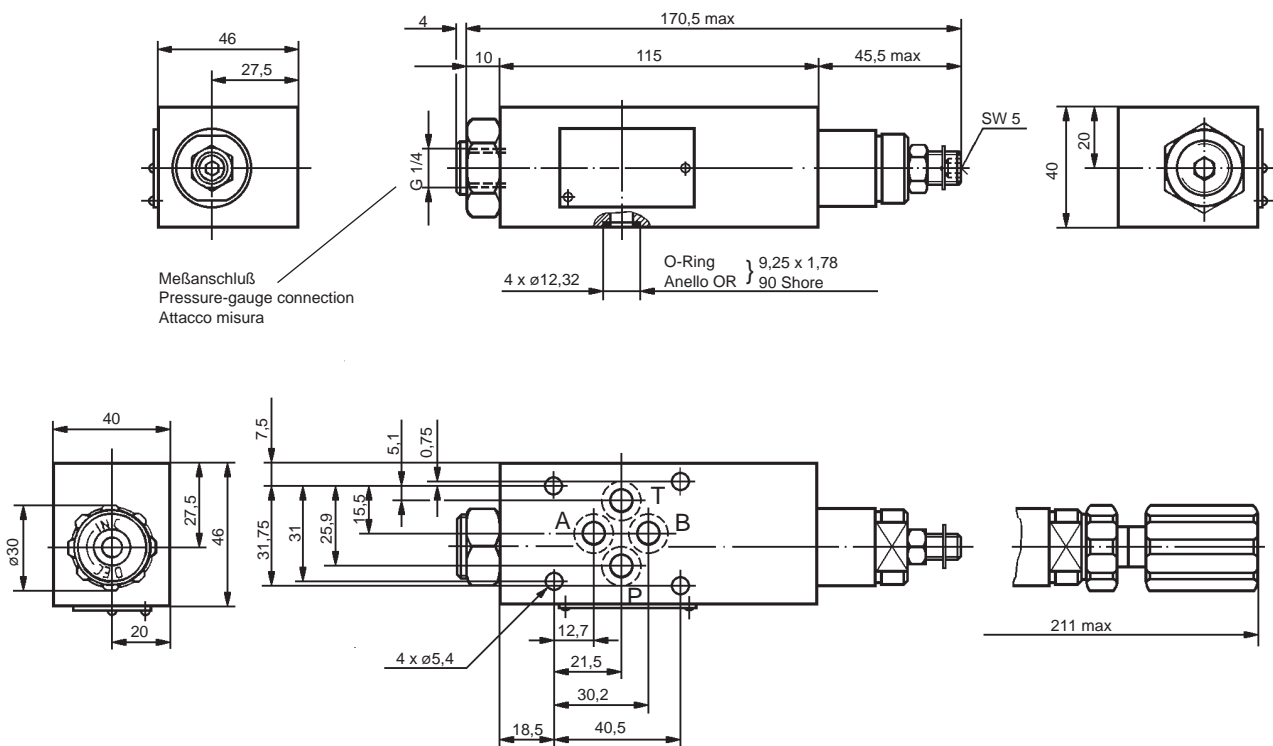

Bild / Fig. 1

Sinnbild · Symbol · Simbolo

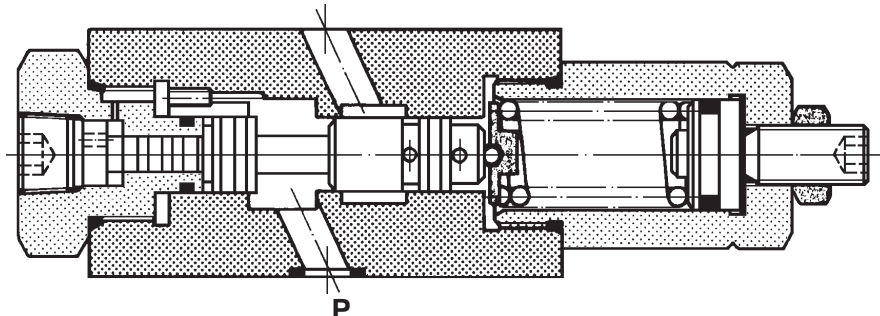

Bild / Fig. 2

Kenngrößen · Operating data · Dati caratteristici

Druckeinstellbereich Pressure adjustment range Campo di regolazione press.	siehe Typenschlüssel see model code vedi chiave di ordinazione	Gewicht Weight Peso	1,1 kg
Max. Betriebsdruck Max. operating pressure Press. di funzionamento max.	250 bar		
Max. Durchfluß Max. flow rate Portata max.	40 L/min		

Typenschlüssel · Model code · Chiave di ordinazione

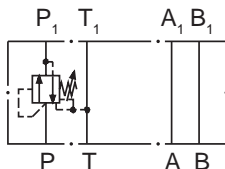
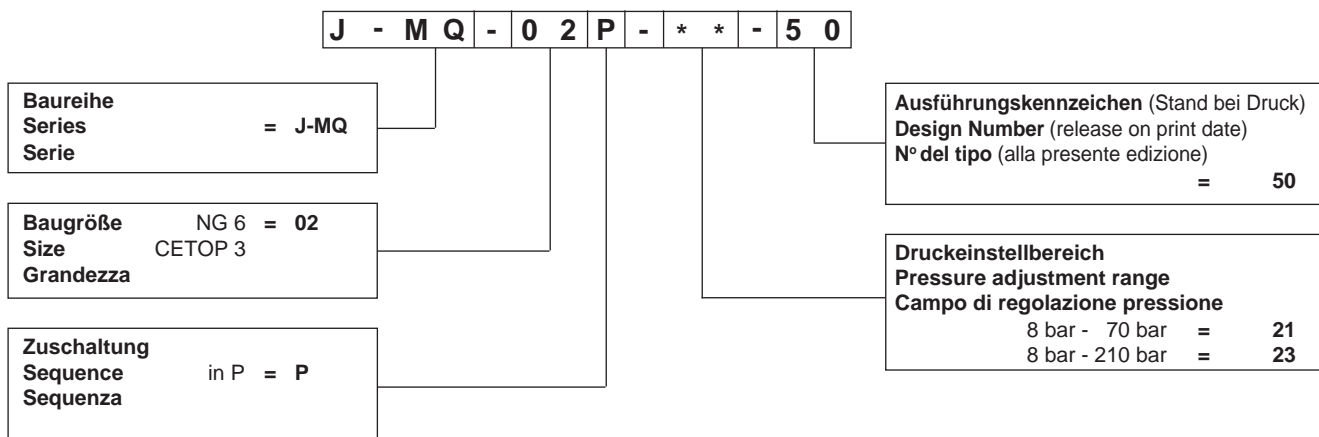

Zwischenplattenventil, NG 6
Multi-stack valve, size 3
Valvola modulare, grandezza 3

Baureihe J-MQ
Series J-MQ
Serie J-MQ

Kennlinien · Characteristics · Curve caratteristiche

ermittelt bei $v = 32 \text{ mm}^2/\text{s}$ · determ. at $v = 32 \text{ mm}^2/\text{s}$ · rilevate con $v = 32 \text{ mm}^2/\text{s}$



Bild / Fig. 3



Bild / Fig. 4

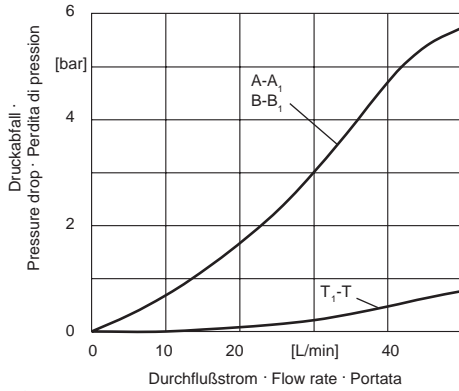

Bild / Fig. 5

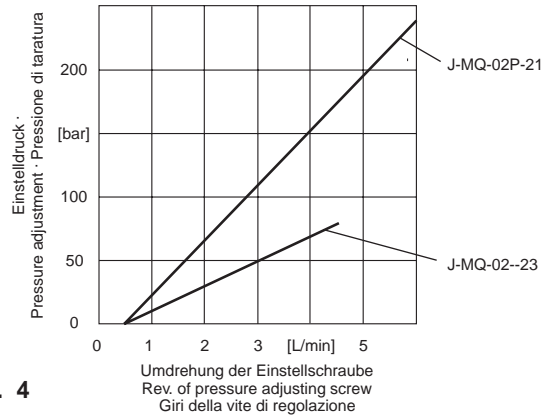

Bild / Fig. 6

Geräteabmessungen · Installation dimensions · Dimensioni

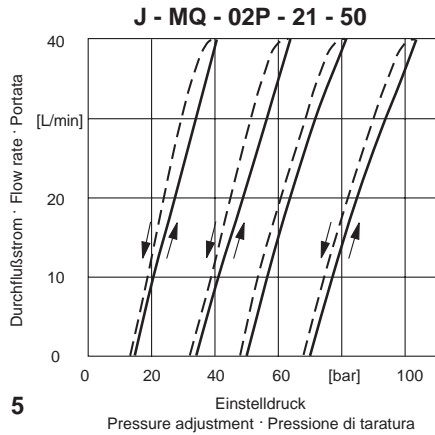

Bild / Fig. 7

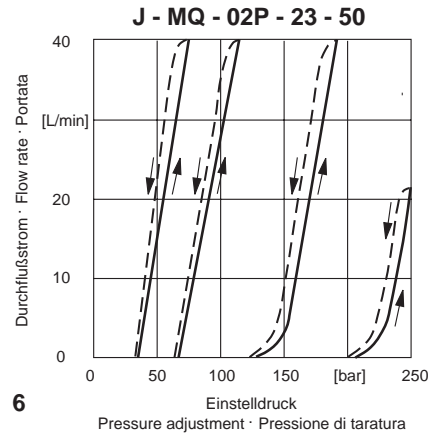
Zwischenplattenventil, NG 6
Multi-stack valve, size 3
Valvola modulare, grandezza 3

Baureihe J-MQC
Series J-MQC
Serie J-MQC

Vorspannventil mit Umgehungs-Rückschlagventil · Counter balance valve with free flow return · Valvola di bilanciamento con ritegno

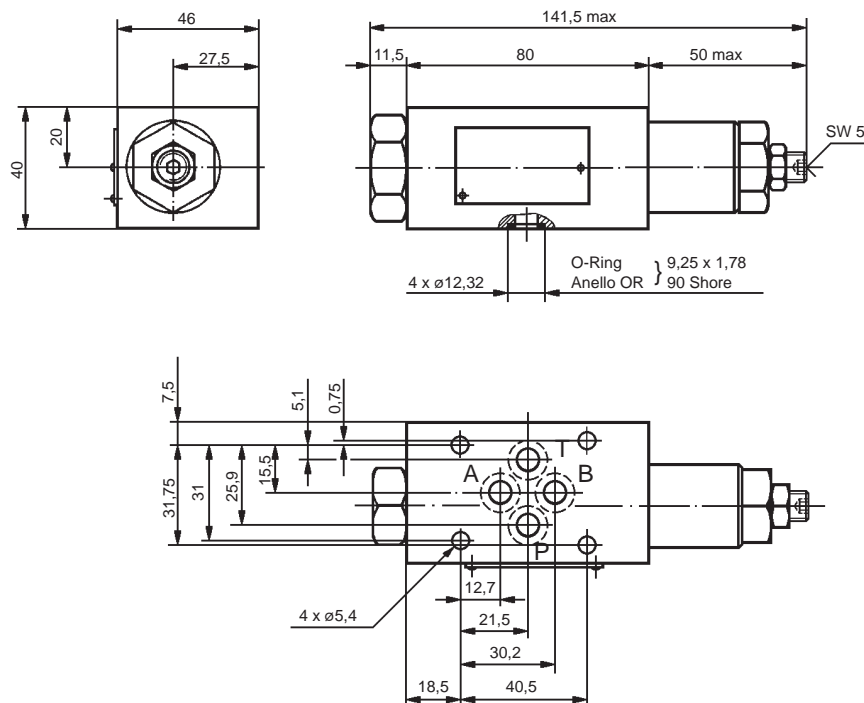

Bild / Fig. 1

Sinnbild · Symbol · Simbolo

J - MQC - 02A - 2 - 60

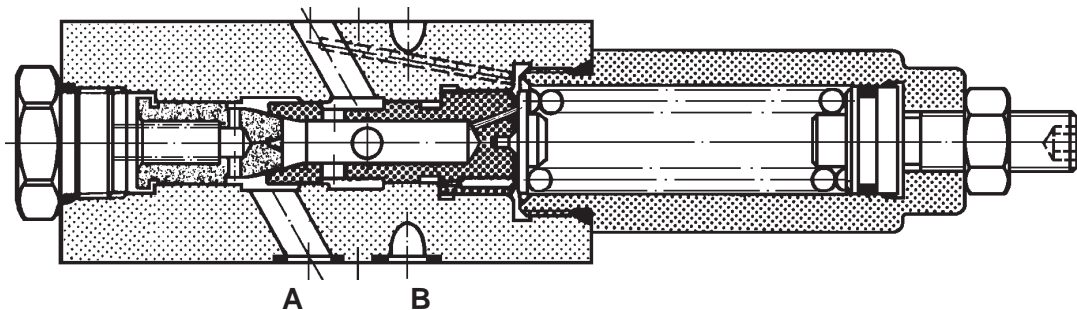

Bild / Fig. 2

J - MQC - 02B - 2 - 60

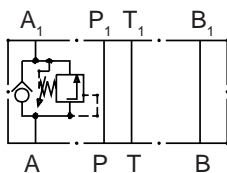

Bild / Fig. 3

Kenngößen · Operating data · Dati caratteristici

Druckeinstellbereich Pressure adjustment range Campo di regolazione press.	siehe Typenschlüssel see model code vedi chiave di ordinazione	Öffnungsdruck Rückschlagventil Cracking pressure check valve Press. d'apertura valvola di non ritorno	0,5 bar
Max. Betriebsdruck Max. operating pressure Press. di funzionamento max.	350 bar	Gewicht Weight Peso	1,35 kg
Max. Durchfluß Max. flow rate Portata max.	40 L/min		

Typenschlüssel · Model code · Chiave di ordinazione

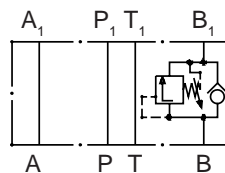
J - M Q C - 0 2 * - 2 - 6 0

Baureihe Series = J-MQC Serie	Ausführungskennzeichen (Stand bei Druck) Design Number (release on print date) N° del tipo (alla presente edizione) = 60
Baugröße NG 6 = 02 Size CETOP 3 Grandezza	Druckeinstellbereich Pressure adjustment range Campo di regolazione pressione 7 bar - 140 bar = 2
Vorspannung in A = A Prestressing in B = B Pre-serraggio	

Zwischenplattenventil, NG 6
Multi-stack valve, size 3
Valvola modulare, grandezza 3

Baureihe J-MQC
Series J-MQC
Serie J-MQC

Kennlinien · Characteristics · Curve caratteristiche

ermittelt bei $v = 32 \text{ mm}^2/\text{s}$ · determ. at $v = 32 \text{ mm}^2/\text{s}$ · rilevate con $v = 32 \text{ mm}^2/\text{s}$



Bild / Fig. 4



Bild / Fig. 5

— Öffnungsdruck
 Cracking pressure
 Press. d'apertura

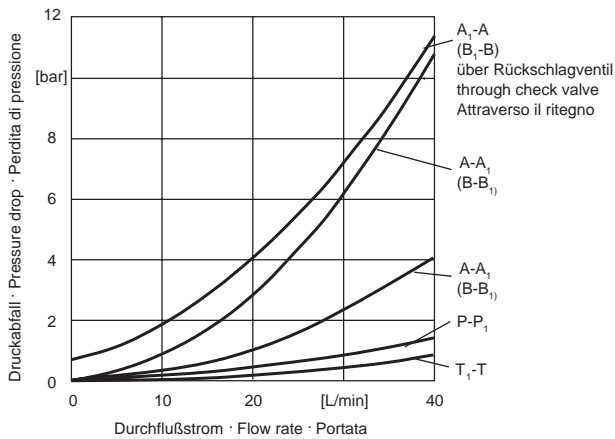
- - - Schließdruck
 Reseat pressure
 Pressione di chiusura

Geräteabmessungen · Installation dimensions · Dimensioni

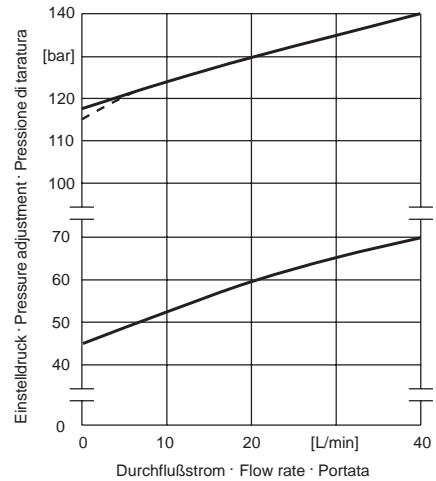

Bild / Fig. 6

Zwischenplattenventil, NG 6
Multi-stack valve, size 3
Valvola modulare, grandezza 3

Baureihe J-MT
Series J-MT
Serie J-MT

Drosselventil · Throttle valve · Strozzatore

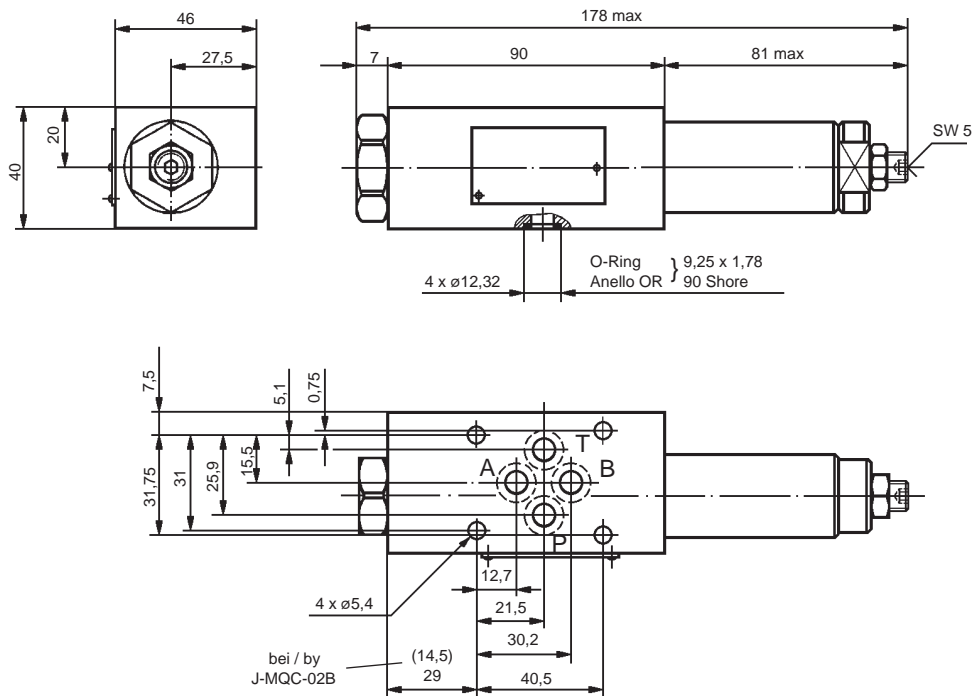

Bild / Fig. 1

Sinnbild · Symbol · Simbolo



Bild / Fig. 2

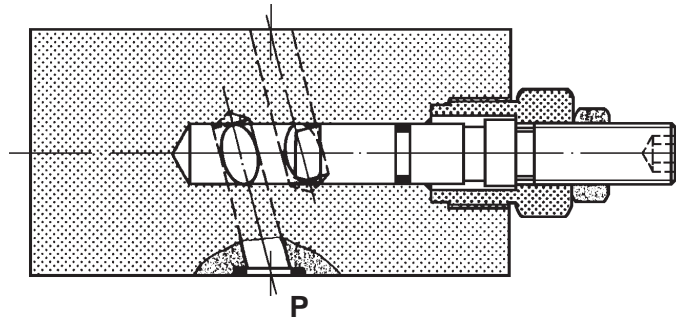

Bild / Fig. 3

Kenngrößen · Operating data · Dati caratteristici

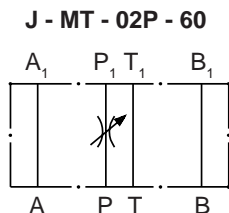
Max. Betriebsdruck Max. operating pressure Press. di funzionamento	350 bar
Max. Durchfluß Max. flow rate Portata max.	40 L/min
Gewicht Weight Peso	1,0 kg 1,2 kg mit Handrad with handwheel con volantino

Verdrehen der Verstellspindel im Uhrzeigersinn =
 abnehmbarer Durchflußstrom
 Verdrehen entgegen Uhrzeigersinn =
 zunehmender Durchflußstrom

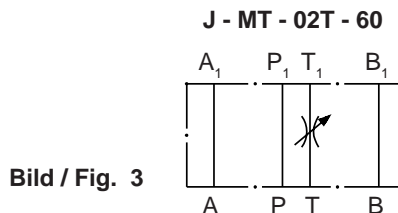
Clockwise rotation of the adjusting screw or handwheel decreases
 flow rate and counter-clockwise rotation increases it.

La rotazione oraria della vite di regolazione o manopola riduce la
 portata e la rotazione anti-oraria la incrementa.

Typenschlüssel · Model code · Chiave di ordinazione

J - M T - 0 2 * - 6 0 - T

Baureihe
Series = J-MT
Serie

Baugröße NG 6 = 02
Size CETOP 3
Grandezza

Vorspannung in P = P
Prestressing in T = T
Pre-serraggio

Verstellung
 mit Werkzeug = ohne Angabe
 mit Handrad = T
Adjustment
 with tool = without instruction
 with handwheel = T
Registrazione
 con utensile = senza specifica
 con volantino = T

Ausführungskennzeichen (Stand bei Druck)
Design Number (release on print date)
N° del tipo (alla presente edizione)
 = 60

Zwischenplattenventil, NG 6
Multi-stack valve, size 3
Valvola modulare, grandezza 3

Baureihe J-MT
Series J-MT
Serie J-MT

Kennlinien · Characteristics · Curve caratteristiche

ermittelt bei $v = 32 \text{ mm}^2/\text{s}$ · determ. at $v = 32 \text{ mm}^2/\text{s}$ · rilevate con $v = 32 \text{ mm}^2/\text{s}$



Bild / Fig. 4

Bild / Fig. 5

Geräteabmessungen · Installation dimensions · Dimensioni

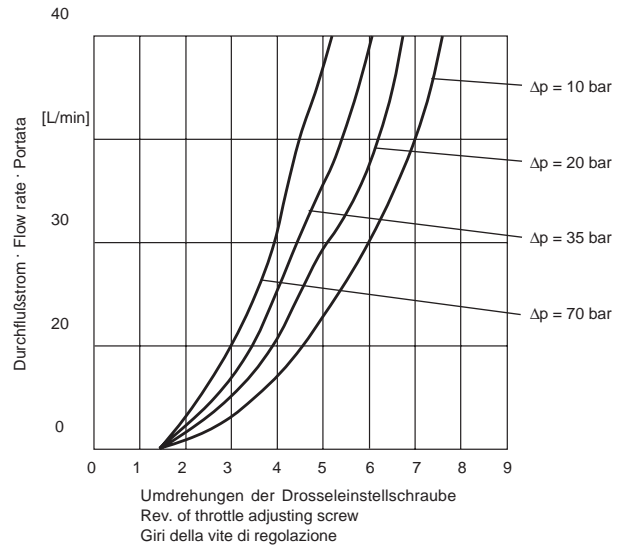
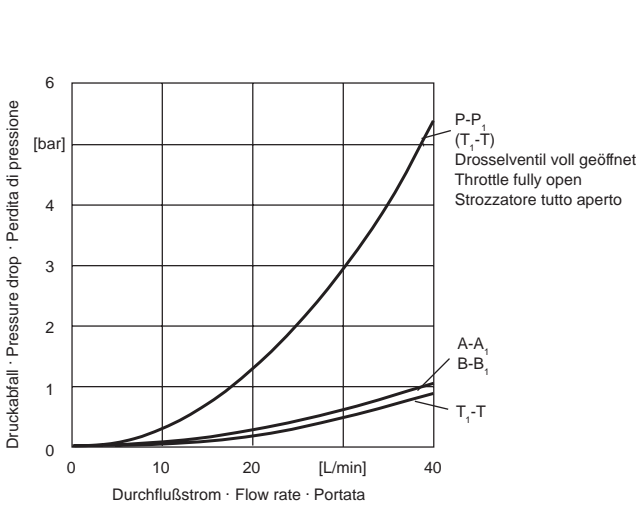

Bild / Fig. 6

Zwischenplattenventil, NG 6
Multi-stack valve, size 3
Valvola modulare, grandezza 3

Baureihe J-MT
Series J-MT
Serie J-MT

Drosselventil mit Umgehungsrückschlagventil · Throttle valve with free flow return check valve ·
Strozzatore con ritegno direzionale

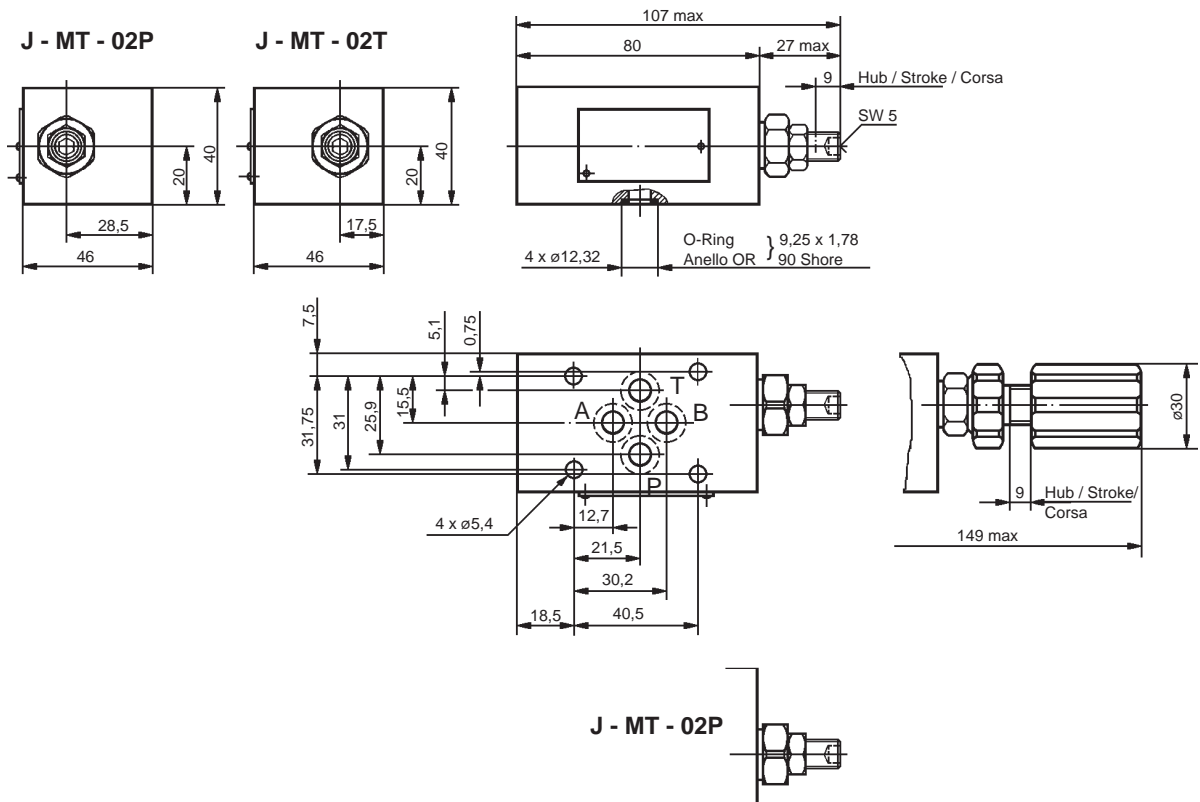

Bild / Fig. 1

Sinnbild · Symbol · Simbolo

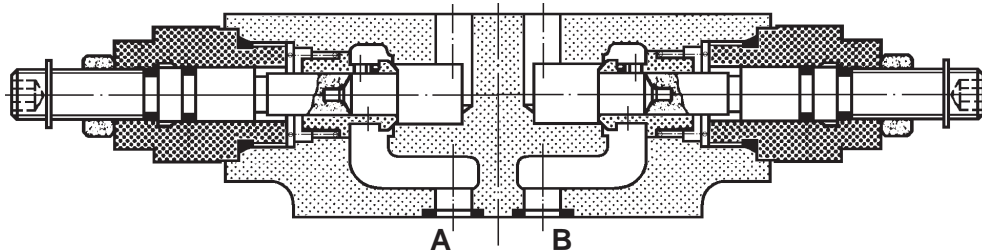
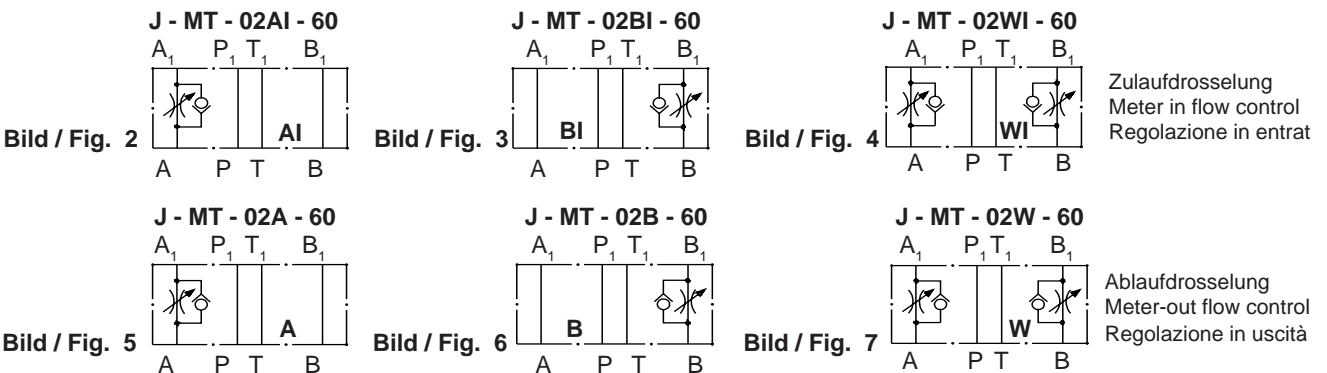

Kenngößen · Operating data · Dati caratteristici

Max. Betriebsdruck Max. operating pressure Press. di funzionamento max.	350 bar
Max. Durchfluß Max. flow rate Portata max.	40 L/min
Öffnungsdruck Rückschlagventil Cracking pressure check valve Press. d'apertura valvola di non ritorno	0,8 bar
Gewicht Weight Peso	1,2 kg 1,4 kg mit Handrad with handwheel con volantino

Verdrehen der Verstellspindel im Uhrzeigersinn =
 abnehmbarer Durchflußstrom
 Verdrehen entgegen Uhrzeigersinn =
 zunehmender Durchflußstrom
 Clockwise rotation of the adjusting screw or handwheel decreases
 flow rate and counter-clockwise rotation increases it.
 La rotazione oraria della vite di regolazione o manopola riduce la
 portata e la rotazione anti-oraria la incrementa.

Typenschlüssel · Model code · Chiave di ordinazione

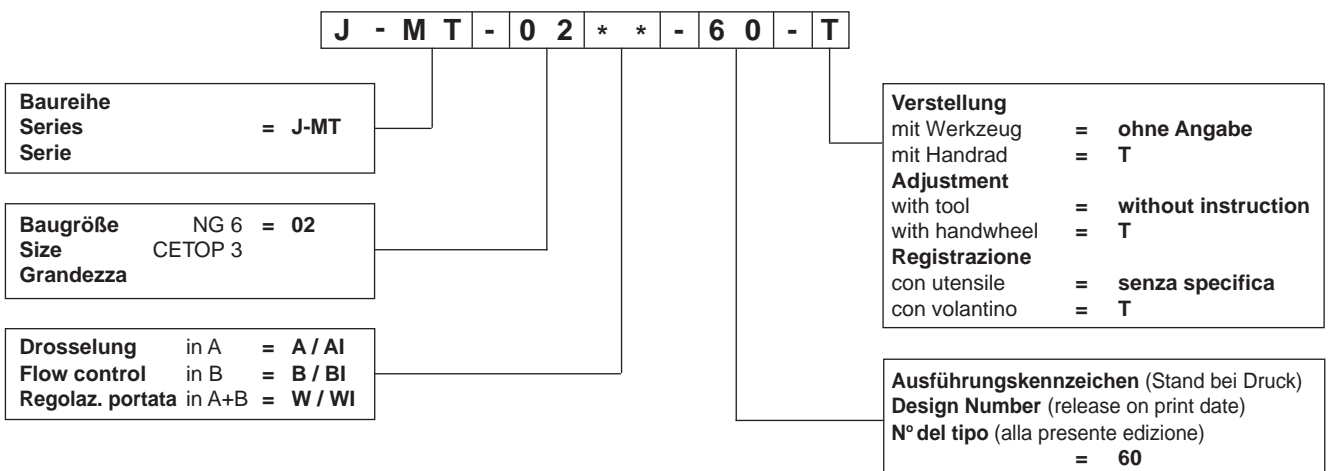

Zwischenplattenventil, NG 6
Multi-stack valve, size 3
Valvola modulare, grandezza 3

Baureihe J-MT
Series J-MT
Serie J-MT

Kennlinien · Characteristics · Curve caratteristiche

ermittelt bei $v = 32 \text{ mm}^2/\text{s}$ · determ. at $v = 32 \text{ mm}^2/\text{s}$ · rilevate con $v = 32 \text{ mm}^2/\text{s}$



Bild / Fig. 8

Bild / Fig. 9

Geräteabmessungen · Installation dimensions · Dimensioni

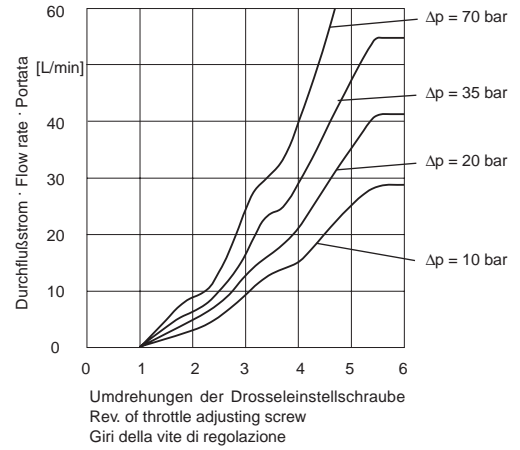
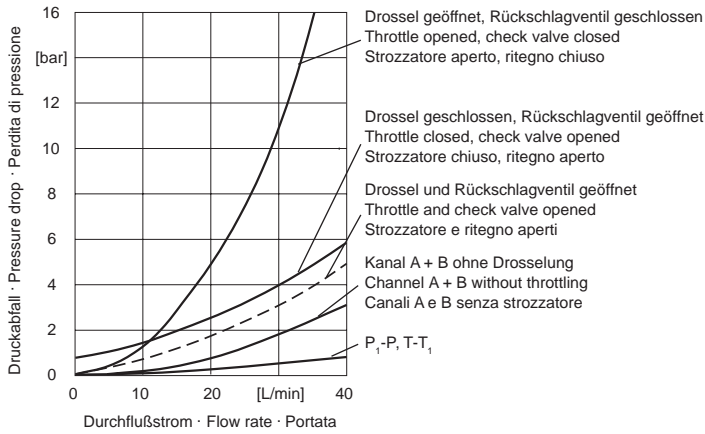

Bild / Fig. 10

Zwischenplattenventil, NG 6
Multi-stack valve, size 3
Valvola modulare, grandezza 3

Baureihe J-MTC
Series J-MTC
Serie J-MTC

Drosselventil mit Rückschlagventil · Throttle valve with check valve ·
Strozzatore con valvola di non ritorno

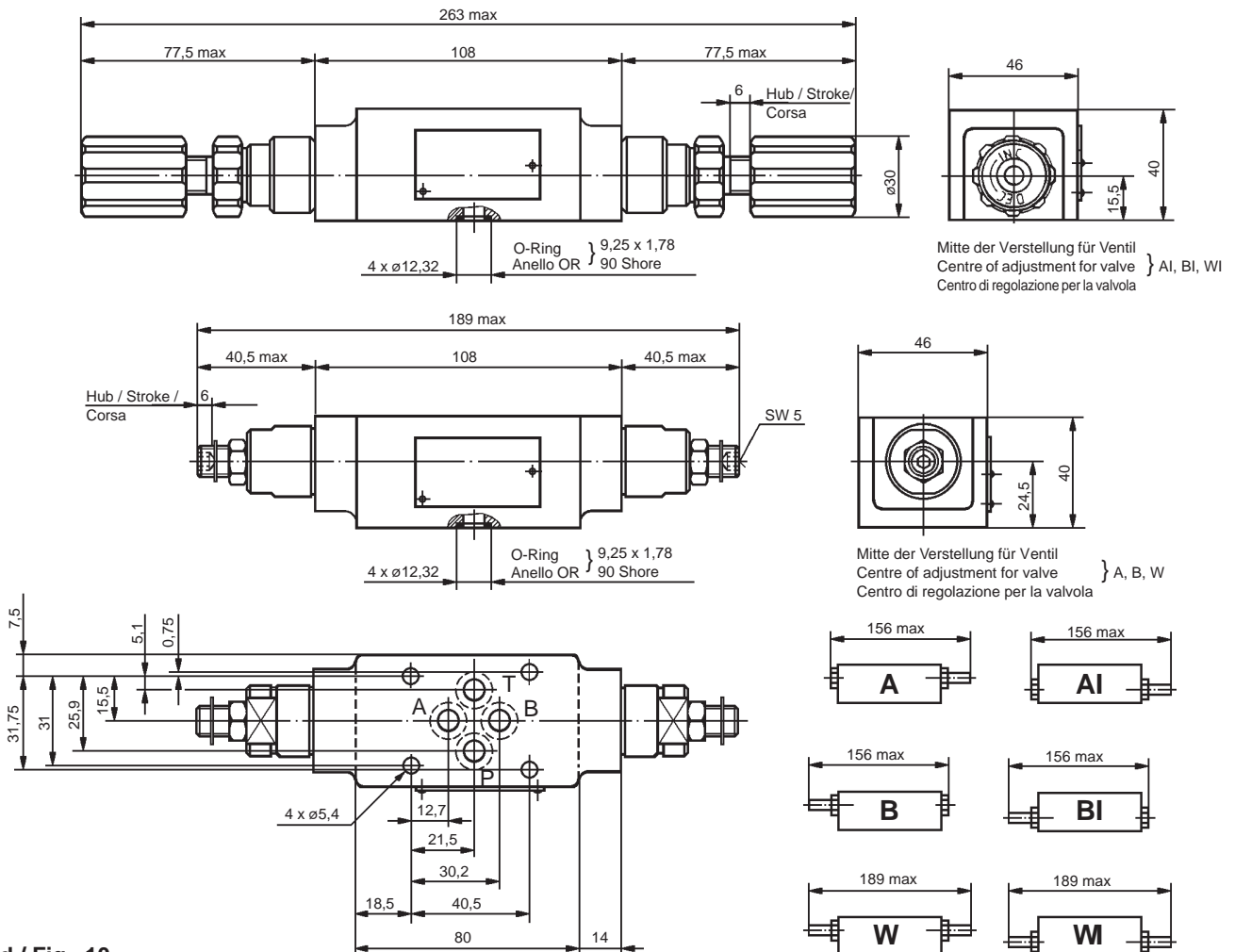

Bild / Fig. 1

Sinnbild · Symbol · Simbolo

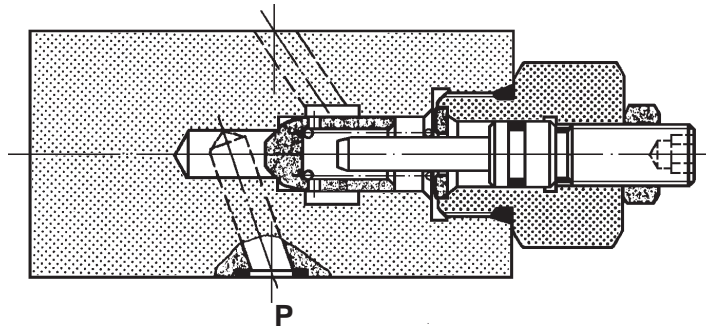

Bild / Fig. 2

Kenngrößen · Operating data · Dati caratteristici

Max. Betriebsdruck Max. operating pressure Press. di funzionamento max.	250 bar
Max. Durchfluß Max. flow rate Portata max.	40 L/min
Öffnungsdruck Rückschlagventil Cracking pressure check valve Press. d'apertura valvola di non ritorno	0,4 bar
Gewicht Weight Peso	1,0 kg

Verdrehen der Verstellspindel im Uhrzeigersinn =
 abnehmbarer Durchflußstrom
 Verdrehen entgegen Uhrzeigersinn =
 zunehmender Durchflußstrom

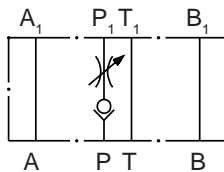
Clockwise rotation of the adjusting screw or handwheel decreases
 flow rate and counter-clockwise rotation increases it.

La rotazione oraria della vite di regolazione o manopola riduce la
 portata e la rotazione anti-oraria la incrementa.

Typenschlüssel · Model code · Chiave di ordinazione

J - M T C - 0 2 P - 5 0

Baureihe
Series = J-MTC
Serie

Baugröße NG 6 = 02
Size CETOP 3
Grandezza

Ausführungskennzeichen (Stand bei Druck)
Design Number (release on print date)
N° del tipo (alla presente edizione)
 = 50

Drosselung in / à P = P
Flow control
Regolazione portata

Zwischenplattenventil, NG 6
Multi-stack valve, size 3
Valvola modulare, grandezza 3

Baureihe J-MTC
Series J-MTC
Serie J-MTC

Kennlinien · Characteristics · Curve caratteristiche

ermittelt bei $v = 32 \text{ mm}^2/\text{s}$ · determ. at $v = 32 \text{ mm}^2/\text{s}$ · rilevate con $v = 32 \text{ mm}^2/\text{s}$



Bild / Fig. 3

Bild / Fig. 4

Geräteabmessungen · Installation dimensions · Dimensioni

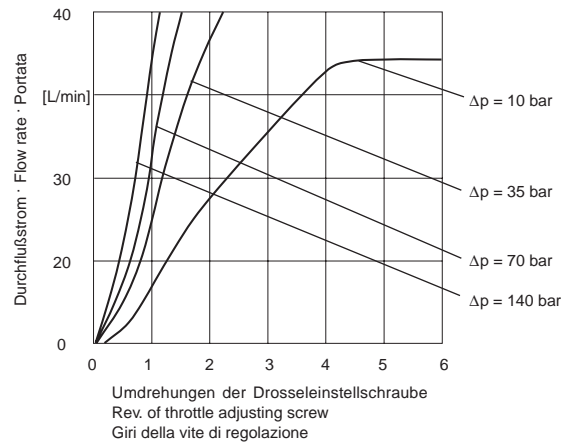
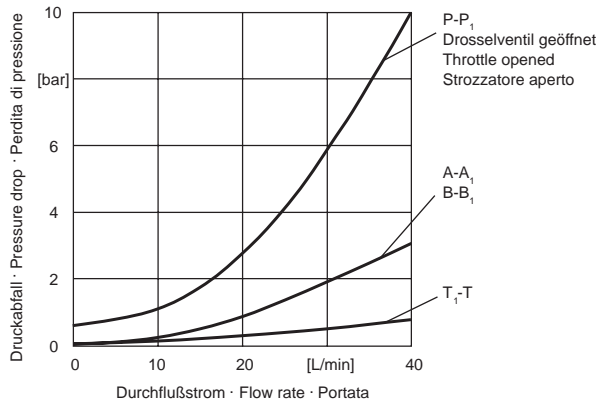

Bild / Fig. 5

Zwischenplattenventil, NG 6
Multi-stack valve, size 3
Valvola modulare, grandezza 3

Baureihe J-MC
Series J-MC
Serie J-MC

Rückschlagventil · Check valve · Valvola di non ritorno

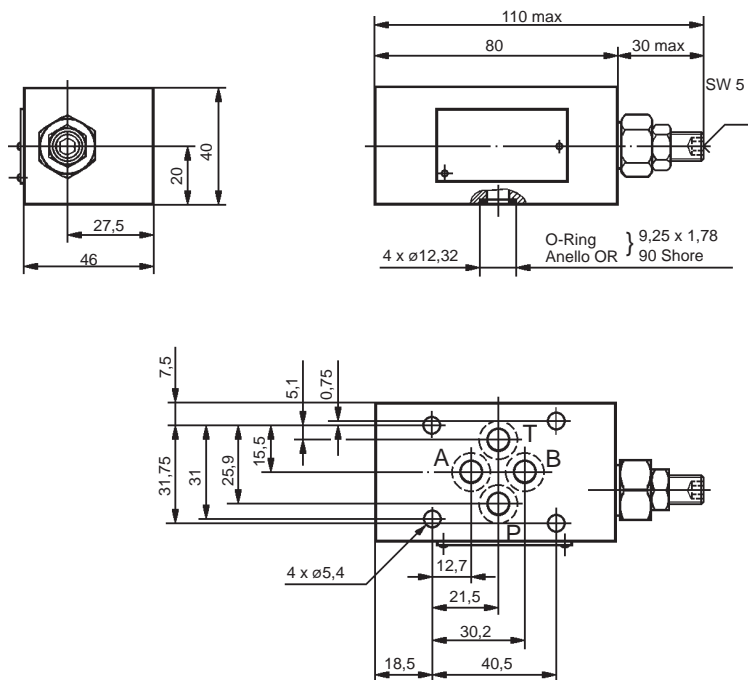

Bild / Fig. 1

Sinnbilder · Symbols · Simbolo

J - MC - 02A - ** - 60

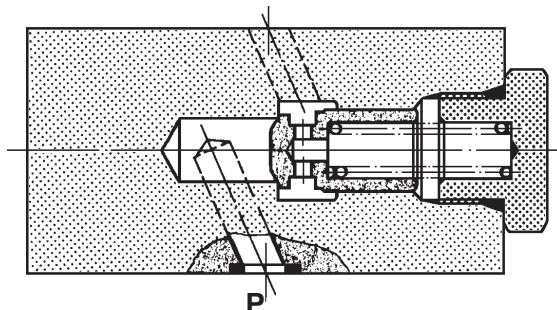

Bild / Fig. 2

J - MC - 02B - ** - 60

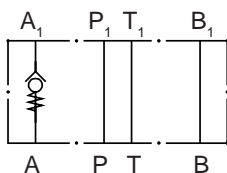

Bild / Fig. 3

J - MC - 02P - ** - 60

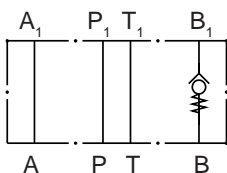

Bild / Fig. 4

J - MC - 02T - ** - 60

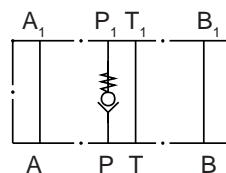

Bild / Fig. 5

Kenngößen · Operating data · Dati caratteristici

Max. Betriebsdruck Max. operating pressure Press. di funzionamento max.	350 bar
Max. Durchfluß Max. flow rate Portata max.	40 L/min
Gewicht Weight Peso	1,0 kg

Typenschlüssel · Model code · Chiave di ordinazione

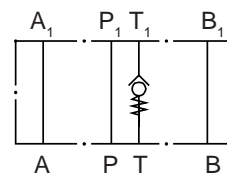
J - M C - 0 2 * - * * - 6 0

Baureihe = J-MC
 Series = J-MC
 Serie

Baugröße NG 6 = 02
 Size CETOP 3
 Grandezza

Sperrung in A = A
 Blocking in B = B
 Blocco in P = P
 in T = T

Ausführungskennzeichen (Stand bei Druck)
 Design Number (release on print date)
 N° del tipo (alla presente edizione)
 = 60

Öffnungsdruck 0,5 bar = 05
 2,0 bar = 20
 Cracking pressure 5,0 bar = 50
 Press. d'apertura

Zwischenplattenventil, NG 6
Multi-stack valve, size 3
Valvola modulare, grandezza 3

Baureihe J-MC
Series J-MC
Serie J-MC

Kennlinien · Characteristics · Curve caratteristiche

ermittelt bei $v = 32 \text{ mm}^2/\text{s}$ · determ. at $v = 32 \text{ mm}^2/\text{s}$ · rilevate con $v = 32 \text{ mm}^2/\text{s}$



Bild / Fig. 6

Bild / Fig. 7

Geräteabmessungen · Installation dimensions · Dimensioni

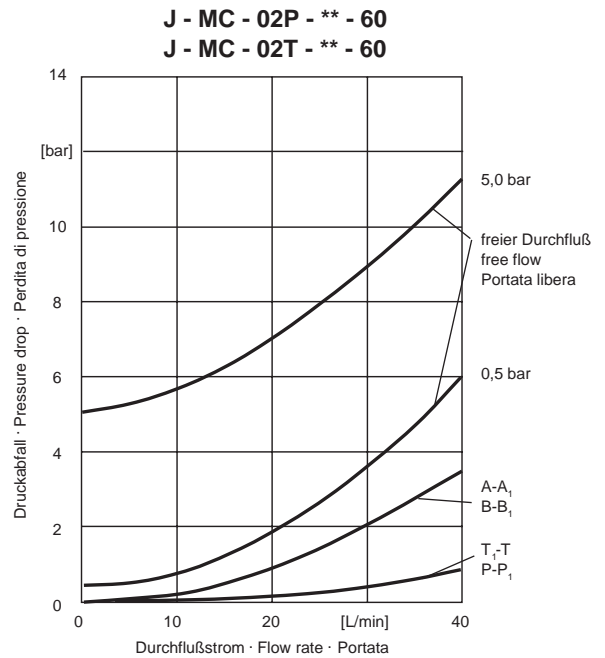
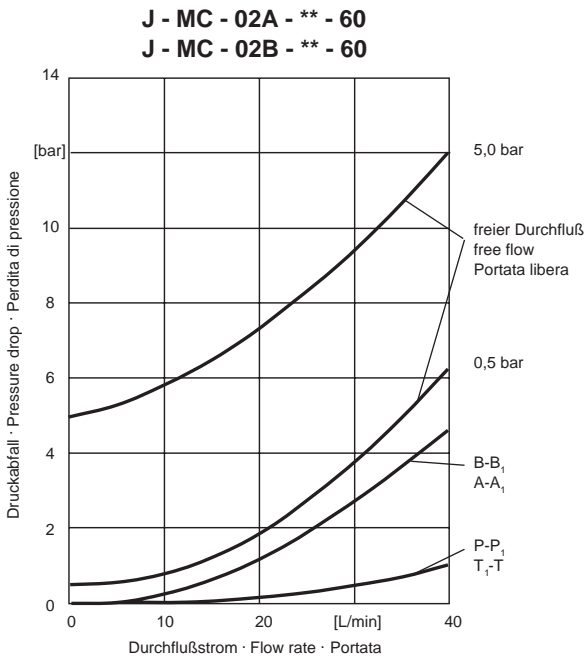

Bild / Fig. 8

Zwischenplattenventil, NG 6
Multi-stack valve, size 3
Valvola modulare, grandezza 3

Baureihe J-MC
Series J-MC
Serie J-MC

Rückschlagventil · Check valve · Valvola di non ritorno

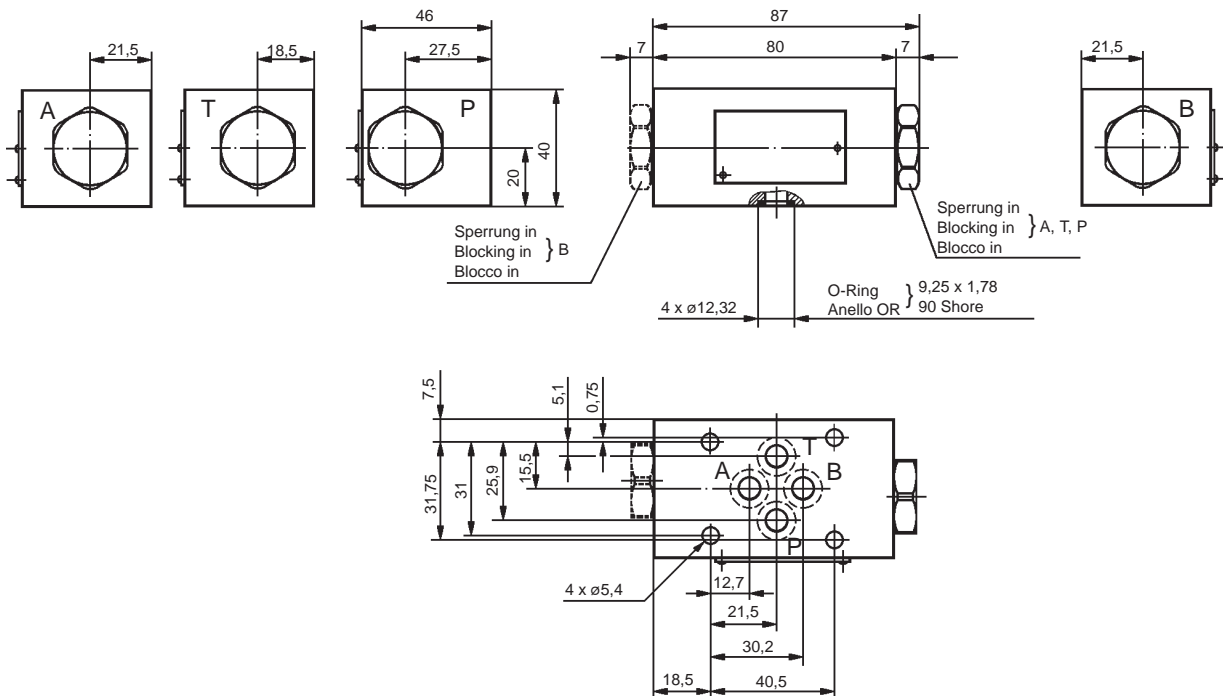
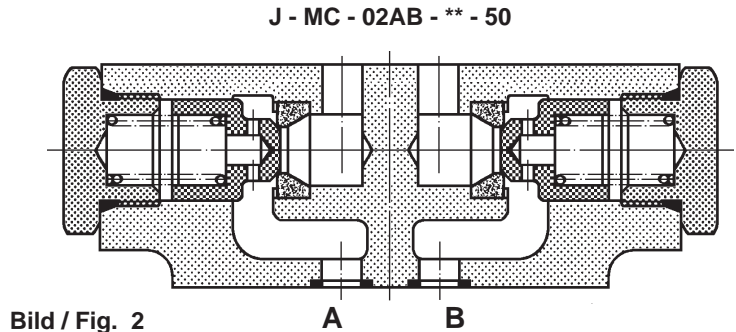
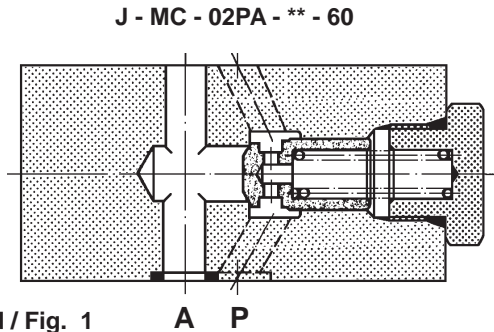

Sinnbild · Symbol · Simbolo



Bild / Fig. 3



Bild / Fig. 4

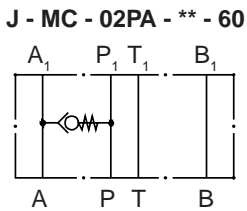

Bild / Fig. 5

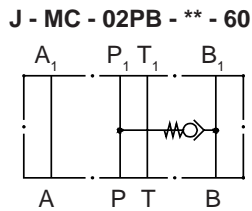

Bild / Fig. 6

Kenngößen · Operating data · Dati caratteristici

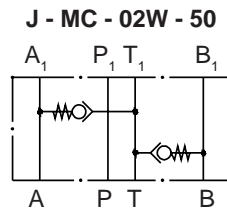
Max. Betriebsdruck Max. operating pressure Press. di funzionamento max.	350 bar* / 250 bar*
Max. Durchfluß Max. flow rate Portata max.	40 L/min
Gewicht Weight Peso	1,0 kg

* 350 bar:
für Ventile mit Ausführungskennzeichen = 60 (siehe Typenschlüssel)
for valves with design no. = 60 (see model code)
per valvole serie 60 (vedi descrittiva)

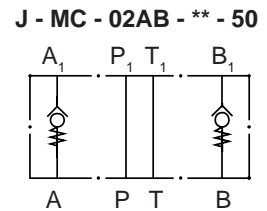
* 250 bar:
für Ventile mit Ausführungskennzeichen = 50 (siehe Typenschlüssel)
for valves with design no. = 50 (see model code)
per valvole serie 60 (vedi descrittiva)

Typenschlüssel · Model code · Chiave di ordinazione

J - M C - 0 2 * * - * * - * *

Baureihe
Series = **J-MC**
Serie

Baugröße NG 6 = **02**
Size CETOP 3
Grandezza

Sperrung · Blocking · Blocco
in P -> A = **PA**
in P -> B = **PB**
in A -> T, B -> T = **W****
in A -> A₁, B -> B₁ = **AB**

Ausführungskennzeichen (Stand bei Druck)
Design Number (release on print date)
N° del tipo (alla presente edizione)

Sperrung in } PA, PB = **60**
Blocking in }
Blocco in }
Sperrung in } W, AB = **50**
Blocking in }
Blocco in }

Öffnungsdruck
Cracking pressure
Press. d'apertura

0,5 bar = **05**
5,0 bar = **50**
für W** per W** 0,15 bar

** keine Öffnungsdruckangabe für Variante W
** no pressure specification for type W
** nessuna specifica di pressione per il tipo W

**Zwischenplattenventil, NG 6
Multi-stack valve, size 3
Valvola modulare, grandezza 3**

**Baureihe J-MC
Series J-MC
Serie J-MC**

Kennlinien · Characteristics · Curve caratteristiche

ermittelt bei $v = 32 \text{ mm}^2/\text{s}$ · determ. at $v = 32 \text{ mm}^2/\text{s}$ · rilevate con $v = 32 \text{ mm}^2/\text{s}$



Bild / Fig. 7

Bild / Fig. 8

Bild / Fig. 9

Geräteabmessungen · Installation dimensions · Dimensioni

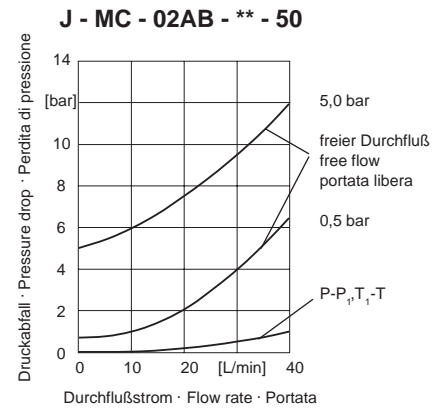
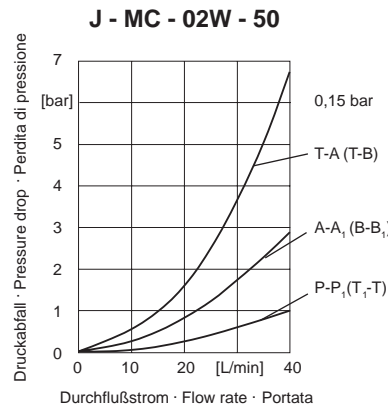
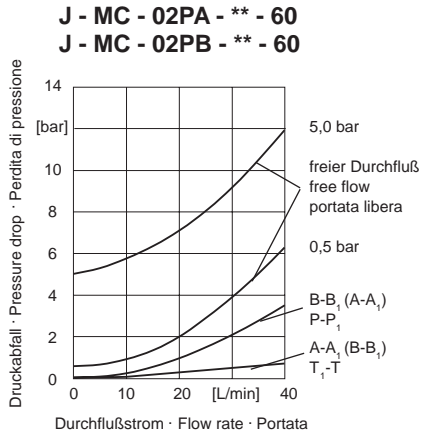

Bild / Fig. 10



Bild / Fig. 11

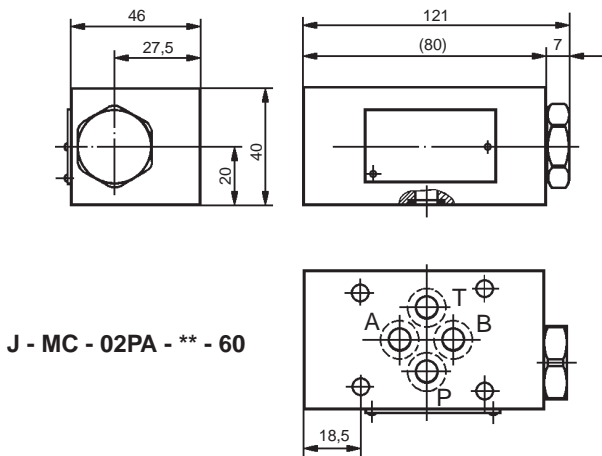

Bild / Fig. 12

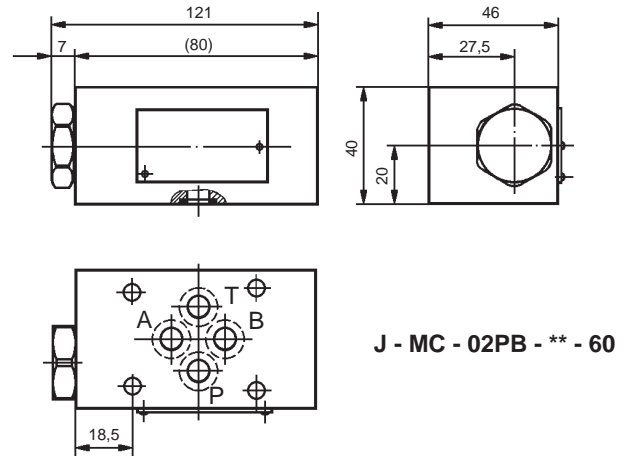

Bild / Fig. 13

**Zwischenplattenventil, NG 6
Multi-stack valve, size 3
Valvola modulare, grandezza 3**

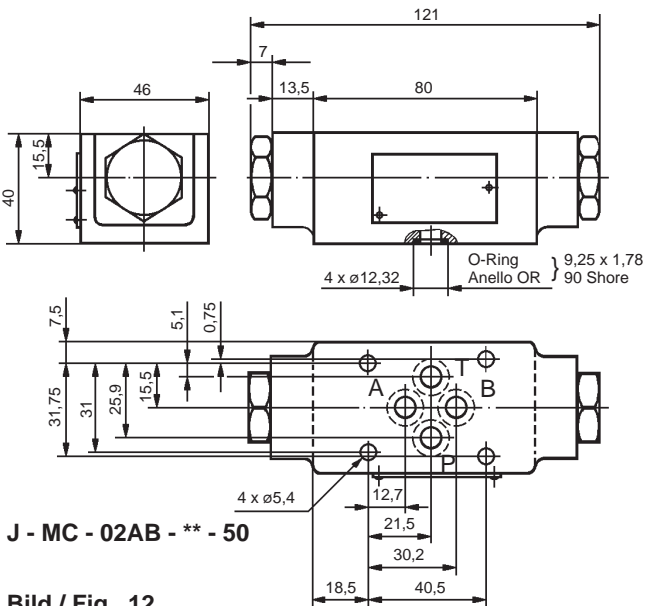
**Baureihe J-MP
Series J-MP
Serie J-MP**

Rückschlagventil, hydraulisch entsperrbar · Pilot operated check valves · Ritegno pilotato

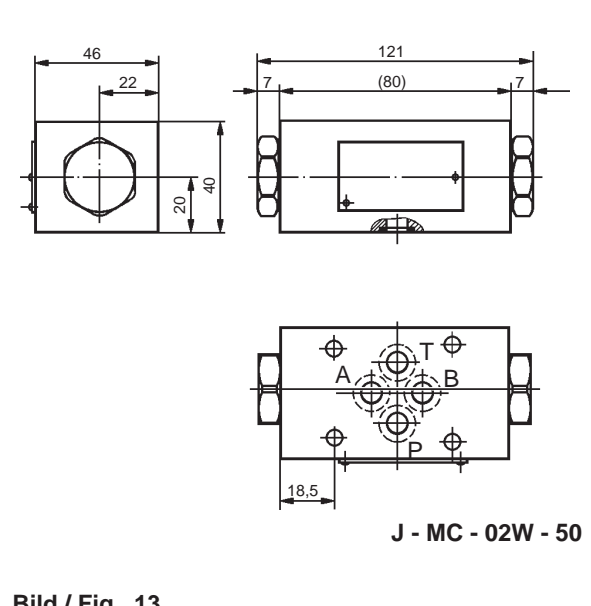

Bild / Fig. 1

Sinnbilder · Symbols · Simbolo

J - MP - 02A - * - * - 60

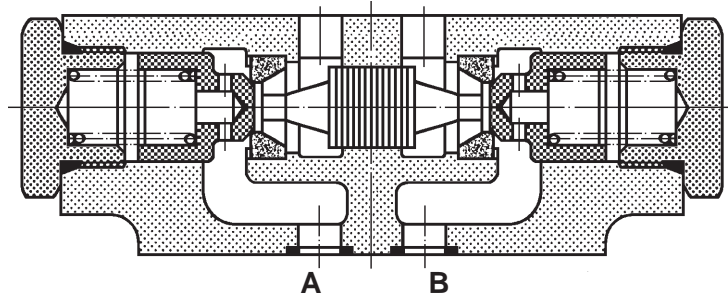

Bild / Fig. 2

J - MP - 02B - * - * - 60

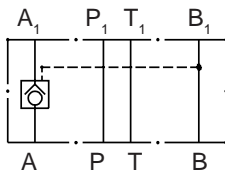

Bild / Fig. 3

J - MP - 02W - * - * - 60

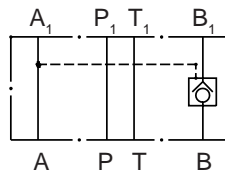

Bild / Fig. 4

Kenngößen · Operating data · Dati caratteristici

Max. Betriebsdruck Max. operating pressure Press. di funzionamento max.	350 bar
Max. Durchfluß Max. flow rate Portata max.	40 L/min
Gewicht Weight Peso	1,2 kg

Flächenverhältnis Steuerkolben zum Ventilsitz } 2,7 : 1
Ratio of area piston / valve seat
Rapporto area pistone / sede

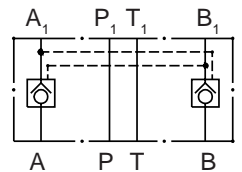
Typenschlüssel · Model code · Chiave di ordinazione

J - M P - 0 2 * - * * - 6 0

Baureihe Series = J-MP Serie	Ausführungskennzeichen = 60 (Stand bei Druck) Design Number (release on print date) N° del tipo (alla presente edizione)
Baugröße NG 6 = 02 Size CETOP 3 Grandezza	Öffnungsdruck 2,0 bar = 20 Cracking pressure 5,0 bar = 50 Press. d'apertura
Sperrung in A = A Blocking in B = B Blocco in A + B = W	

Zwischenplattenventil, NG 6
Multi-stack valve, size 3
Valvola modulare, grandezza 3

Baureihe J-MP
Series J-MP
Serie J-MP

Kennlinien · Characteristics · Curve caratteristiche

ermittelt bei $v = 32 \text{ mm}^2/\text{s}$ · determ. at $v = 32 \text{ mm}^2/\text{s}$ · rilevate con $v = 32 \text{ mm}^2/\text{s}$



Bild / Fig. 5



Bild / Fig. 6

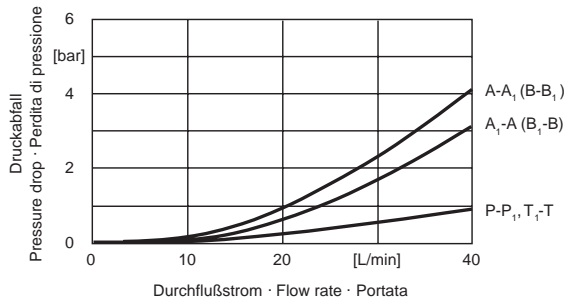

Bild / Fig. 7

Geräteabmessungen · Installation dimensions · Dimensioni

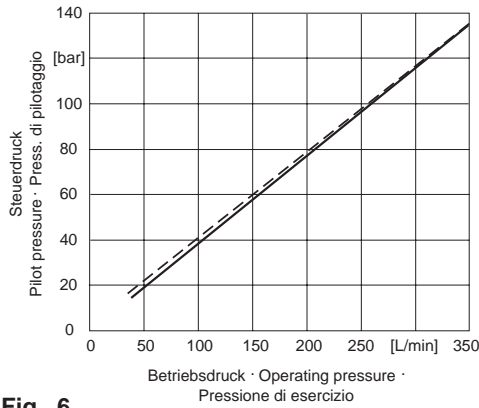

Bild / Fig. 8

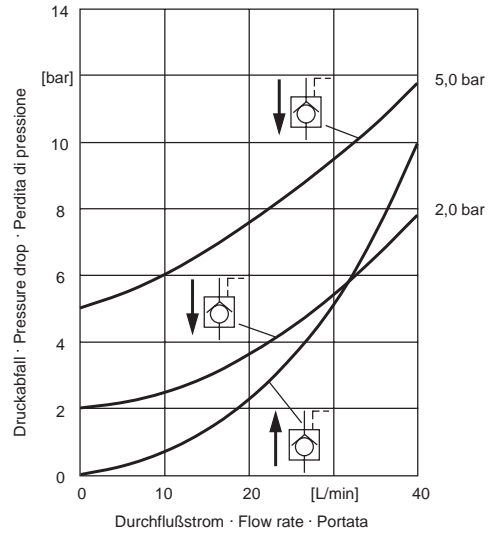
Zwischenplattenventil, NG 6
Multi-stack valve, size 3
Valvola modulare, grandezza 3

Baureihe J-MPD
Series J-MPD
Serie J-MPD

Rückschlagventil, hydraulisch entsperrbar mit Vorentlastung · Pilot operated check valve with decompression · Ritegno pilotato con decompressione

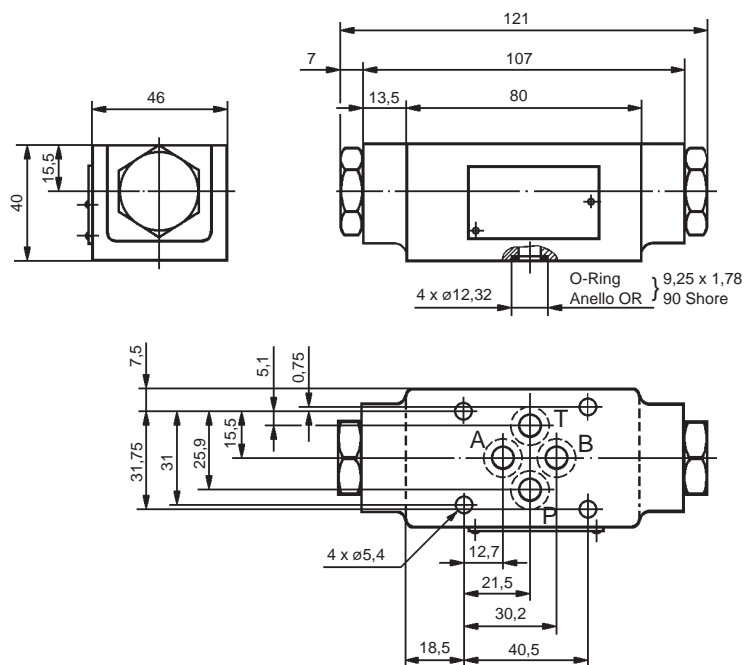

Bild / Fig. 1

Sinnbilder · Symbols · Simbolo

J - MPD - 02A - ** - 50

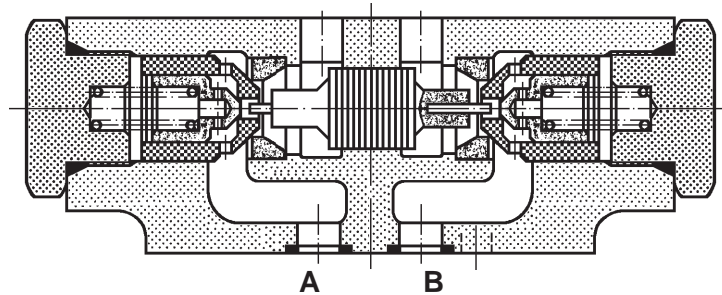

Bild / Fig. 2

J - MPD - 02B - ** - 50

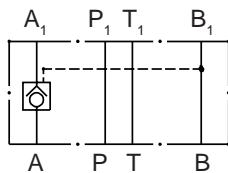

Bild / Fig. 3

J - MPD - 02W - ** - 50

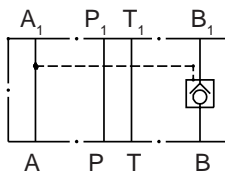

Bild / Fig. 4

Kenngößen · Operating data · Dati caratteristici

Max. Betriebsdruck Max. operating pressure Press. di funzionamento	250 bar
Max. Durchfluß Max. flow rate Portata max.	40 L/min
Gewicht Weight Peso	1,2 kg

Flächenverhältnis Steuerkolben zum Ventilsitz
 Ratio of area piston / valve seat
 Rapporto area pistone / sede valvola

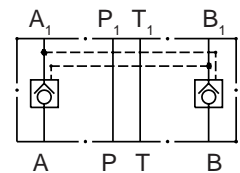
- a) Vorsteuerventil
Pilot valve
Valvola di pilotaggio } 16 : 1
- b) Hauptventil
Main valve
Valvola principale } 1,96 : 1

Typenschlüssel · Model code · Chiave di ordinazione

J - M P D - 0 2 * - * * - 5 0

Baureihe
Series = J-MPD
Serie

Baugröße NG 6 = 02
Size CETOP 3
Grandezza

Sperrung in A = A
Blocking in B = B
Blocco in A + B = W

Ausführungskennzeichen = 50
(Stand bei Druck)
Design Number (release on print date)
N° del tipo (alla presente edizione)

Öffnungsdruck 2,0 bar = 20
Cracking pressure 5,0 bar = 50
Press. d'apertura

Zwischenplattenventil, NG 6
Multi-stack valve, size 3
Valvola modulare, grandezza 3

Baureihe J-MPD
Series J-MPD
Serie J-MPD

Kennlinien · Characteristics · Curve caratteristiche

ermittelt bei $v = 32 \text{ mm}^2/\text{s}$ · determ. at $v = 32 \text{ mm}^2/\text{s}$ · rilevate con $v = 32 \text{ mm}^2/\text{s}$



Bild / Fig. 5



Bild / Fig. 6

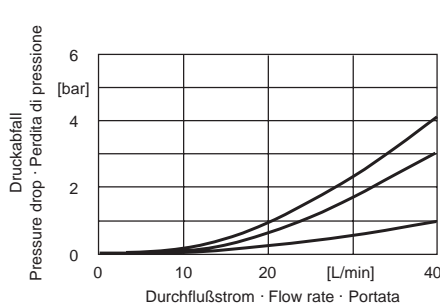

Bild / Fig. 7

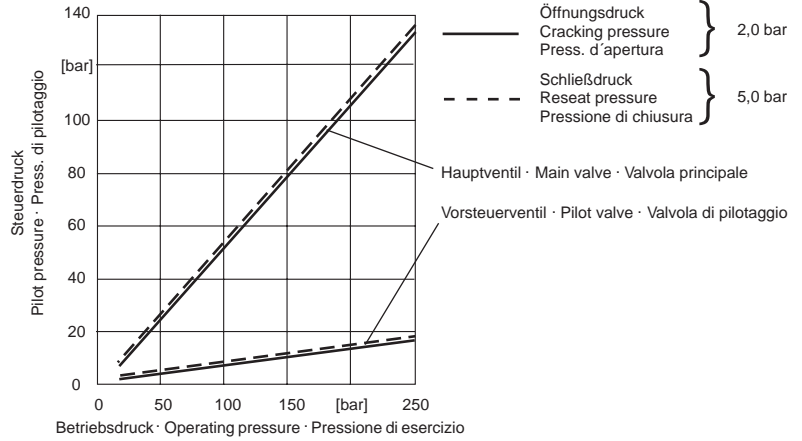

Bild / Fig. 8

Geräteabmessungen · Installation dimensions · Dimensioni

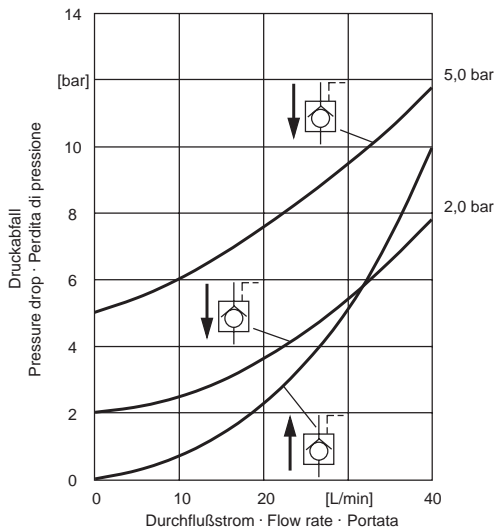

Bild / Fig. 9

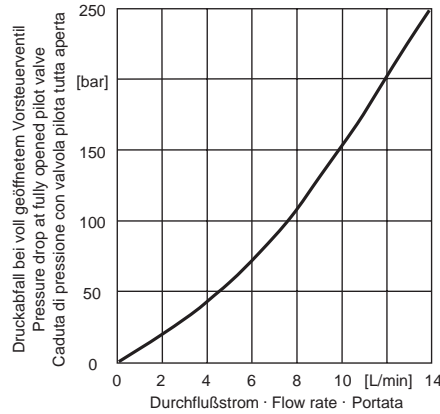
Zwischenplattenventil, NG 6

Multi-stack valve, size 3

Valvola modulare, grandezza 3

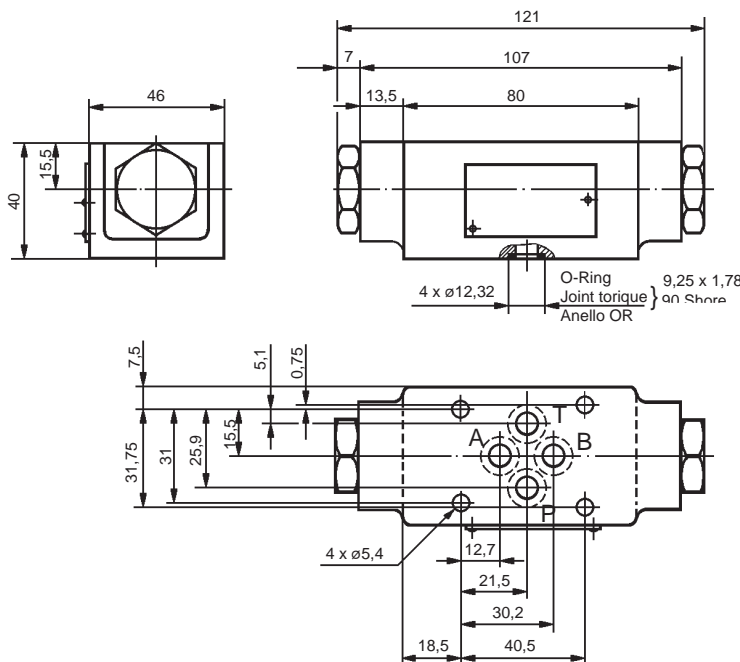
Zusatzplatten · Subplates · Piastrre aggiuntive

Sinnbilder · Symbols · Simbolo / Typenschlüssel · Model code · Chiave di ordinazione







	Abschlußplatte · Cover block Piastra di chiusura J-BS-02-60		Umlenkplatte · Bypass block Piastra di adattamento J-BF-02-60
	Umlenkplatte · Bypass block Piastra di adattamento J-BE-02-60		Umlenkplatte · Bypass block Piastra di adattamento J-BD-02PA-60
	Umlenkplatte · Bypass block Piastra di adattamento J-BH-02-60		Umlenkplatte · Bypass block Piastra di adattamento J-BD-02PT-60
	Abzweigplatte · Gauge block Attacco manometro J-BG-02PT-60		Umlenkplatte · Bypass block Piastra di adattamento J-BG-02AB-60

Tabelle 1 / Table 1 / Tabella 1

Kenngößen · Operating data · Dati caratteristici

Max. Betriebsdruck Max. operating pressure Press. di funzionamento max.	350 bar	Gewicht Weight Peso	1,0 kg
Max. Durchfluß Max. flow rate Portata max.	40 L/min		

Geräteabmessungen · Installation dimensions · Dimensioni

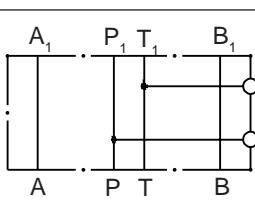
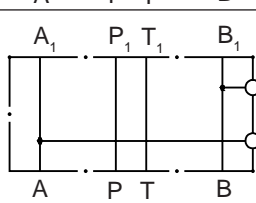

Bild / Fig. 1

Zwischenplattenventil, NG 6

Multi-stack valve, size 3

Valvola modulare, grandezza 3

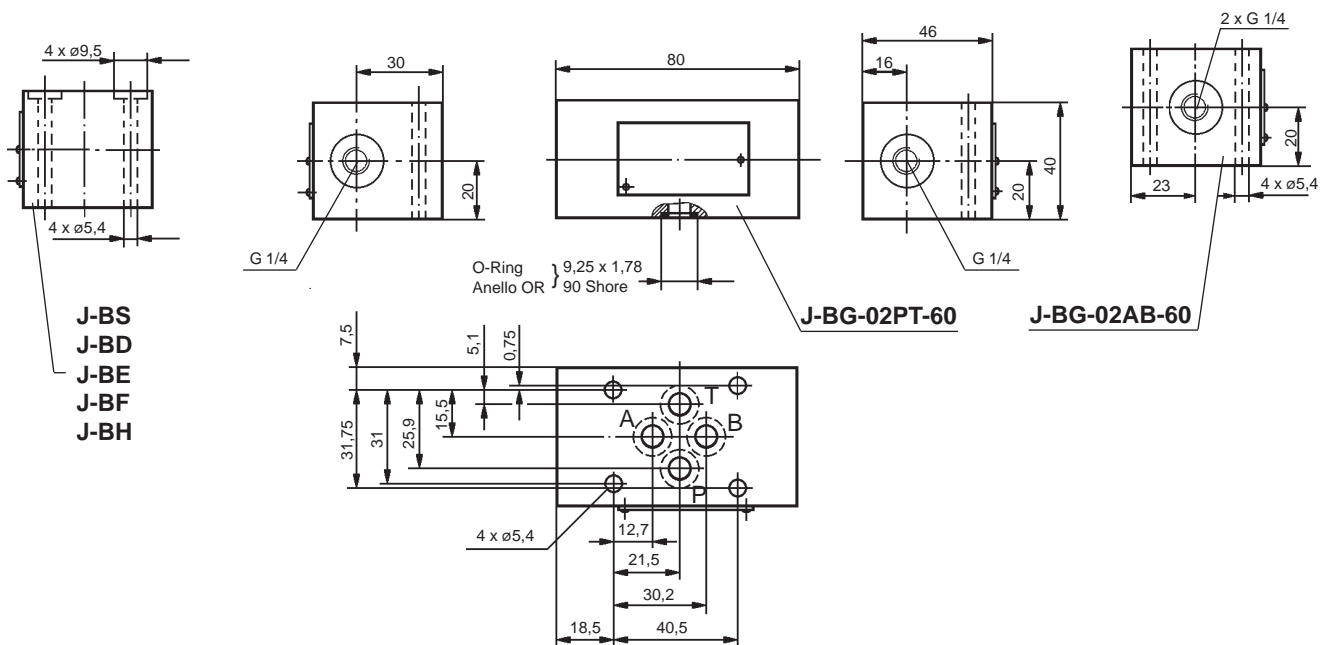
Sammelanschlußplatten · Manifold plates · Piastre multiple

Sinnbild · Symbol · Simbolo

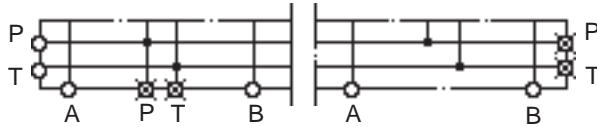

Kenngößen · Operating data · Dati caratteristici

Max. Betriebsdruck Max. operating pressure Press. di funzionamento max.	350 bar
Max. Durchfluß Max. flow rate Portata max.	40 L/min

Gewicht Weight Peso	siehe Typenschlüssel see Model code vedi chiave di ordinazione
---------------------------	--

Typenschlüssel · Model code · Chiave di ordinazione

	Anzahl der Stationen No. of stations N.° di stazioni	M*	L*	Gewicht Weight Peso	} kg
J-BT-102-60	1	0	88	2,7	
J-BT-202-60	2	50	130	4,2	
J-BT-302-60	3	100	180	6,0	
J-BT-402-60	4	150	230	7,8	
J-BT-502-60	5	200	280	9,6	
J-BT-602-60	6	250	330	11,4	

* siehe Seite 33
see page 33
vedi pagina 33

Größere Abmessungen auf Anfrage / Other dimensions on inquiry / Altre dimensioni su richiesta

Geräteabmessungen · Installation dimensions · Dimensioni



Bild / Fig. 1

Zwischenplattenventil, NG 6
Multi-stack valve, size 3
Valvola modulare, grandezza 3

Geräteabmessungen · Installation dimensions · Dimensioni

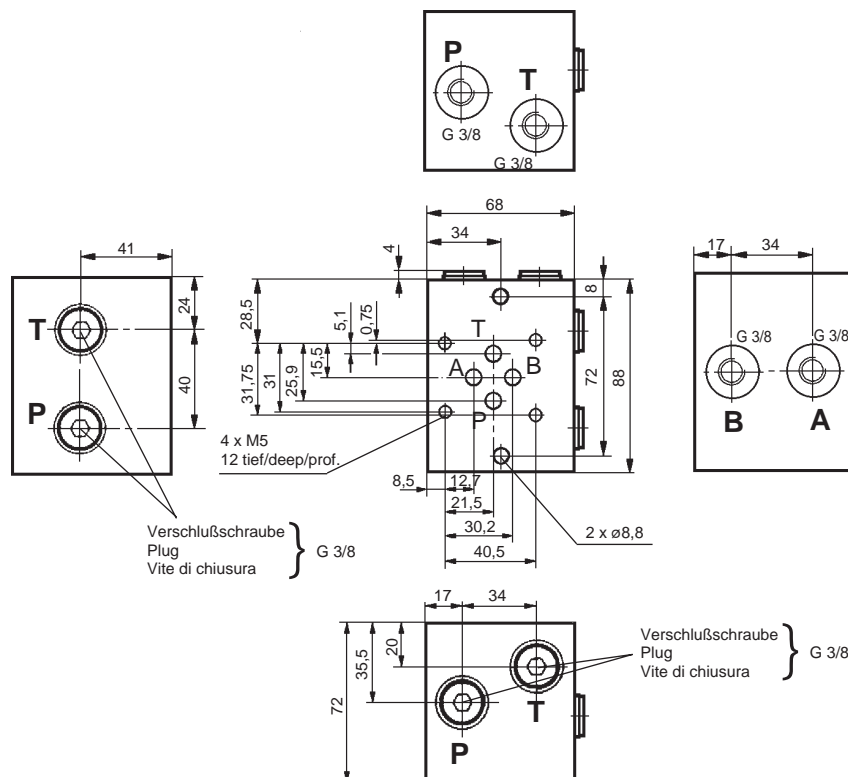

Bild / Fig. 2

Zubehör · Accessories · Accessori

Befestigungsschrauben* Fixing bolts* Viti di fissaggio*			
I_H	Zylinderschraube Cylinder screw Vite a testa cilindrica	Anzugsmoment Tightening torque coppia di serraggio	Best.-Nr. Part.-no No. d'ordinaz.
0	4 x M5 x 45 DIN 912 - 10.9		742866
40	4 x M5 x 85 DIN 912 - 10.9	5 Nm bis 8 Nm	742874
80	4 x M5 x 125 DIN 912 - 10.9	5 Nm to 8 Nm	742882
120	4 x M5 x 165 DIN 912 - 10.9	5 Nm ... 8 Nm	742890
160	4 x M5 x 205 DIN 912 - 10.9		742908

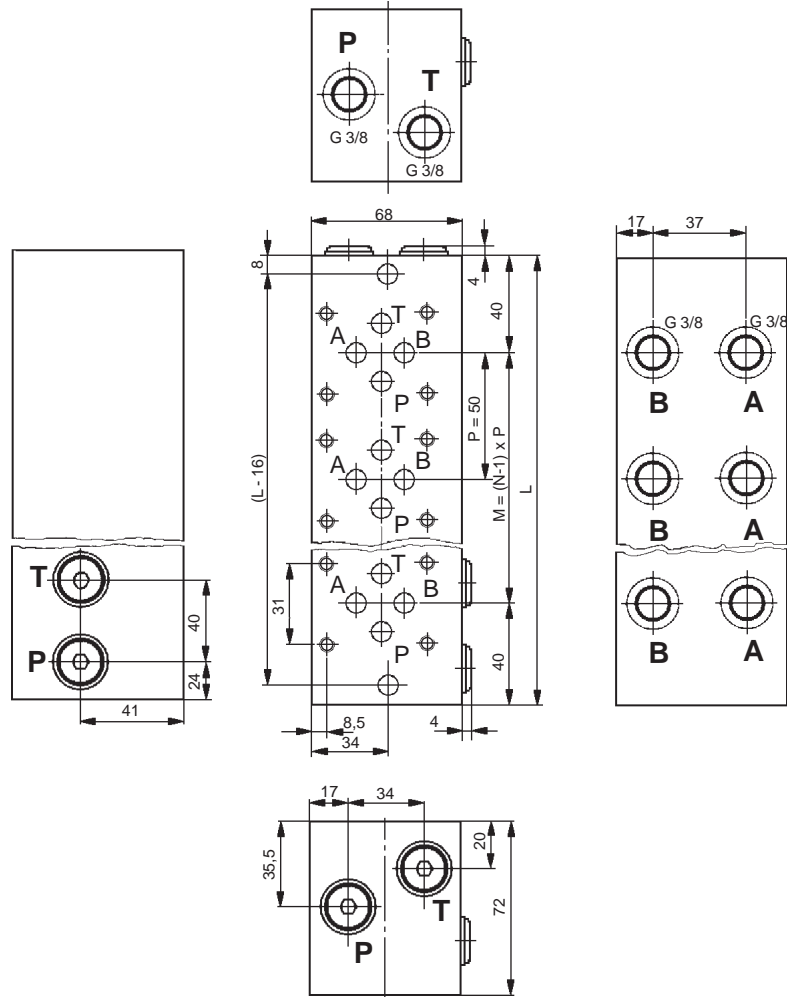
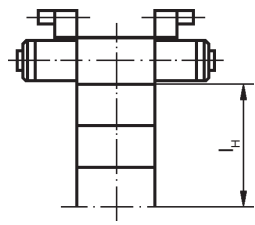

* Gehört nicht zum Lieferumfang / * not included in delivery scope / *Non compreso nell'insieme di fornitura

Zwischenplattenventil, NG 10
Multi-stack valve, size 5
Valvola modulare, grandezza 5

Baureihe J-MR
Series J-MR
Serie J-MR

Druckbegrenzungsventil, vorgesteuert · Pilot operating pressure relief valves ·
Valvola di massima pressione pilotata



Bild / Fig. 1

Sinnbilder · Symbols · Simbolo

	Druckbegrenzung in P Pressure relief in P Limitazione di pressione in P		
--	---	--	--

Bild / Fig. 2

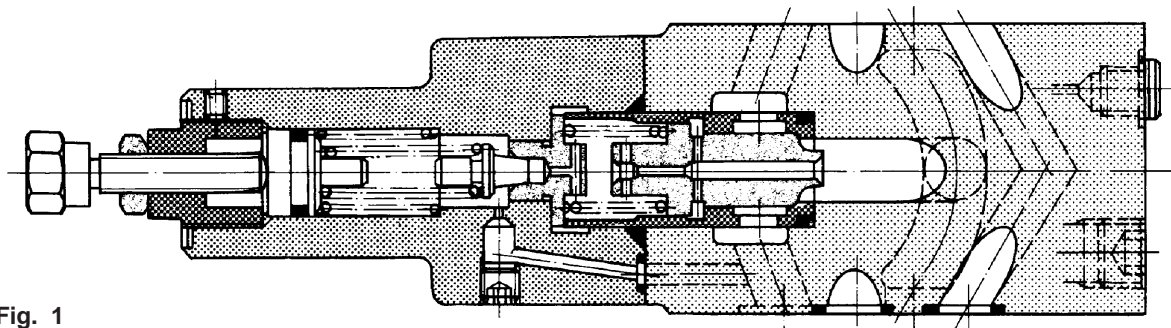
Kenngößen · Operating data · Dati caratteristici

Druckeinstellbereich Pressure adjustment range Campo di regolazione press.	siehe Typenschlüssel see model code vedi chiave di ordinazione	Gewicht Weight Peso	3,4 kg 3,4 kg mit Handrad with handwheel con volantino
Max. Betriebsdruck Max. operating pressure Press. di funzionamento max.	350 bar		
Max. Durchfluß Max. flow rate Portata max.	80 L/min		

Typenschlüssel · Model code · Chiave di ordinazione

J - M R - 0 3 P - * - 4 0 - T

Baureihe Series = J-MR Serie	Verstellung mit Werkzeug = ohne Angabe mit Handrad = T Adjustment with tool = without instruction with handwheel = T
Baugröße NG 10 = 03 Size CETOP 5 Grandezza	Registrazione con utensile = senza specifica con volantino = T
Druckbegrenzung Pressure relief Limitazione di pressione in P = P	Ausführungskennzeichen (Stand bei Druck) Design Number (release on print date) N° del tipo (alla presente edizione) = 40
Druckeinstellbereich Pressure adjustment range Campo di regolazione pressione 7 bar - 70 bar = 1 35 bar - 250 bar = 3	

Zwischenplattenventil, NG 10
Multi-stack valve, size 5
Valvola modulare, grandezza 5

Baureihe J-MG
Series J-MG
Serie J-MG

Druckregelventil, vorgesteuert · Pilot operating pressure control valve ·
Valvola di riduzione pressione pilotata



Bild / Fig. 1

Sinnbilder · Symbols · Simbolo

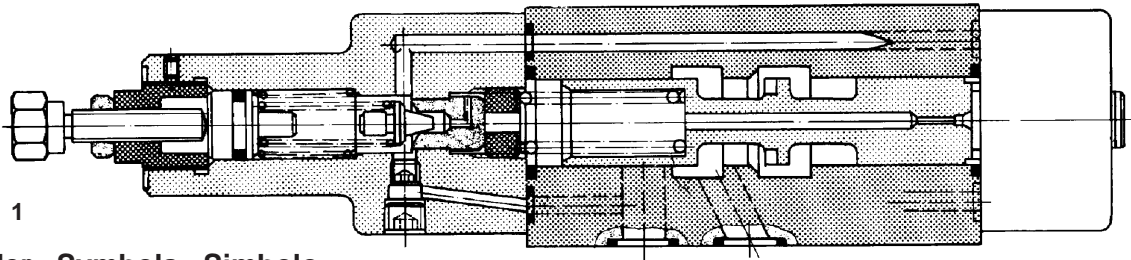

Bild / Fig. 2

** unbedingt extern abführen · use external drain port · è necessario lo scarico esterno

Kenngößen · Operating data · Dati caratteristici

Druckeinstellbereich Pressure adjustment range Campo di regolazione press.	siehe Typenschlüssel see model code vedi chiave di ordinazione
Max. Betriebsdruck Max. operating pressure Press. di funzionamento max.	350 bar
Max. Durchfluß Max. flow rate Portata max.	80 L/min

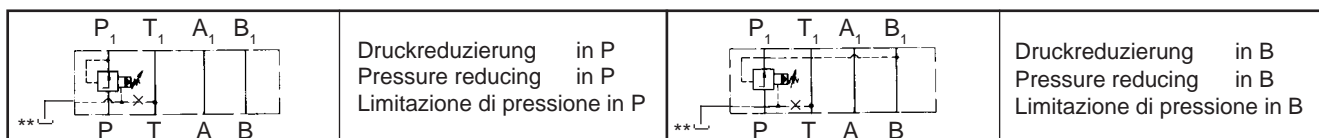
Gewicht Weight with handwheel	4 kg 4 kg mit Handrad Peso con volantino
-------------------------------------	--

Hinweis: Standard mit externem Leckölabfluß - interner Leckölabfluß auf Anfrage
 Notice: Standard with external drain port - internal drain port on request
 Nota: Standard con drenaggio esterno - drenaggio interno su richiesta

Typenschlüssel · Model code · Chiave di ordinazione

J - M G - 0 3 * - * - 4 0 - T - X

Baureihe Series Serie = J-MG	interner Leckölabfluß internal leakage scarico interno = X
Baugröße NG 10 = 03 Size CETOP 5 Grandezza	Verstellung mit Werkzeug = ohne Angabe mit Handrad = T Adjustment with tool = without instruction with handwheel = T
Druckreduzierung Pressure relief Limitazione di pressione in P = P in B = B	Registrazione con utensile = senza specifica con volantino = T
	Ausführungskennzeichen (Stand bei Druck) Design Number (release on print date) N° del tipo (alla presente edizione) = 40
	Druckeinstellbereich Pressure adjustment range Campo di regolazione pressione * 3 bar - 70 bar = 03 7 bar - 70 bar = 1 35 bar - 250 bar = 3

* bei max. Betriebsdruck 160 bar
 at max. operating pressure 160 bar
 alla pressione di esercizio max. di 160 bar
 aufgrund Regelverhalten können bei höheren Drücken keine 3 bar mehr realisiert werden
 in case of higher pressure, it's not possible to realize 3 bar because of controller action
 per il processo di regolazione non sono realizzabili 3 bar con pressioni più alte

Zwischenplattenventil, NG 10
Multi-stack valve, size 5
Valvola modulare, grandezza 5

Baureihe J-MG
Series J-MG
Serie J-MG

Kennlinien · Characteristics · Curve caratteristiche

ermittelt bei $v = 32 \text{ mm}^2/\text{s}$ · determined $v = 32 \text{ mm}^2/\text{s}$ · rilevate $v = 32 \text{ mm}^2/\text{s}$



Bild / Fig. 3

Geräteabmessungen · Installation dimensions · Dimensioni

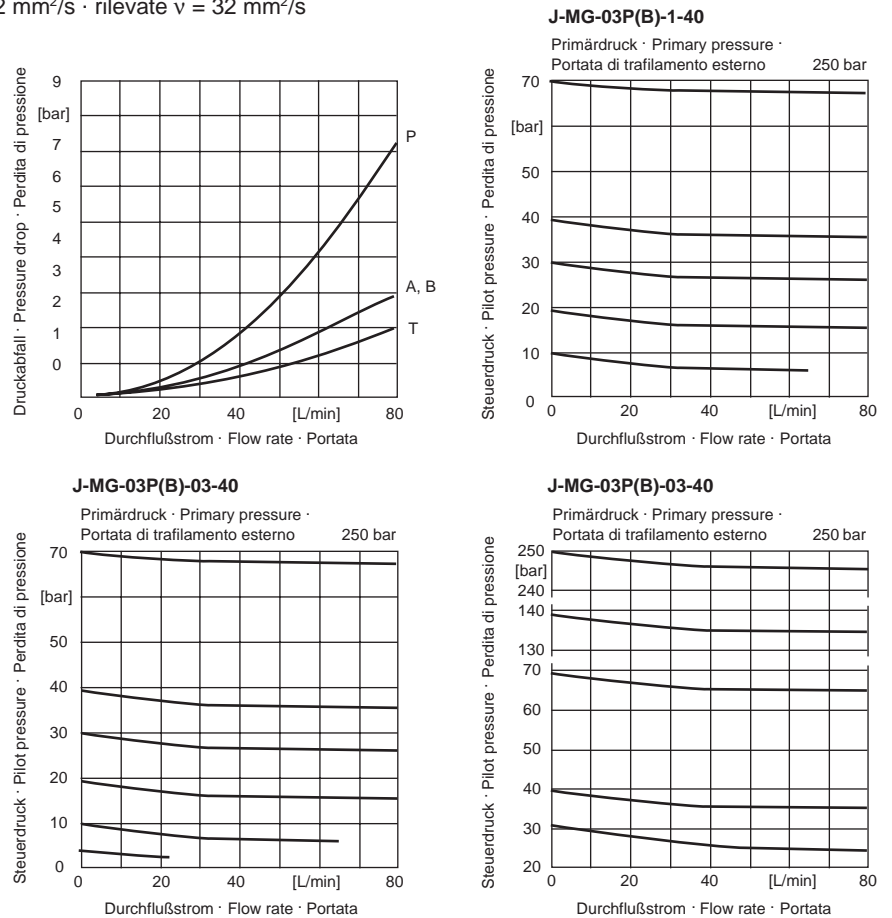

Bild / Fig. 4

Zwischenplattenventil, NG 10
Multi-stack valve, size 5
Valvola modulare, grandezza 5

Baureihe J-MQ
Series J-MQ
Serie J-MQ

Druckfolgeventil, direkt gesteuert · Direct operating sequence valve ·
Valvola di sequenza a pilotaggio diretto

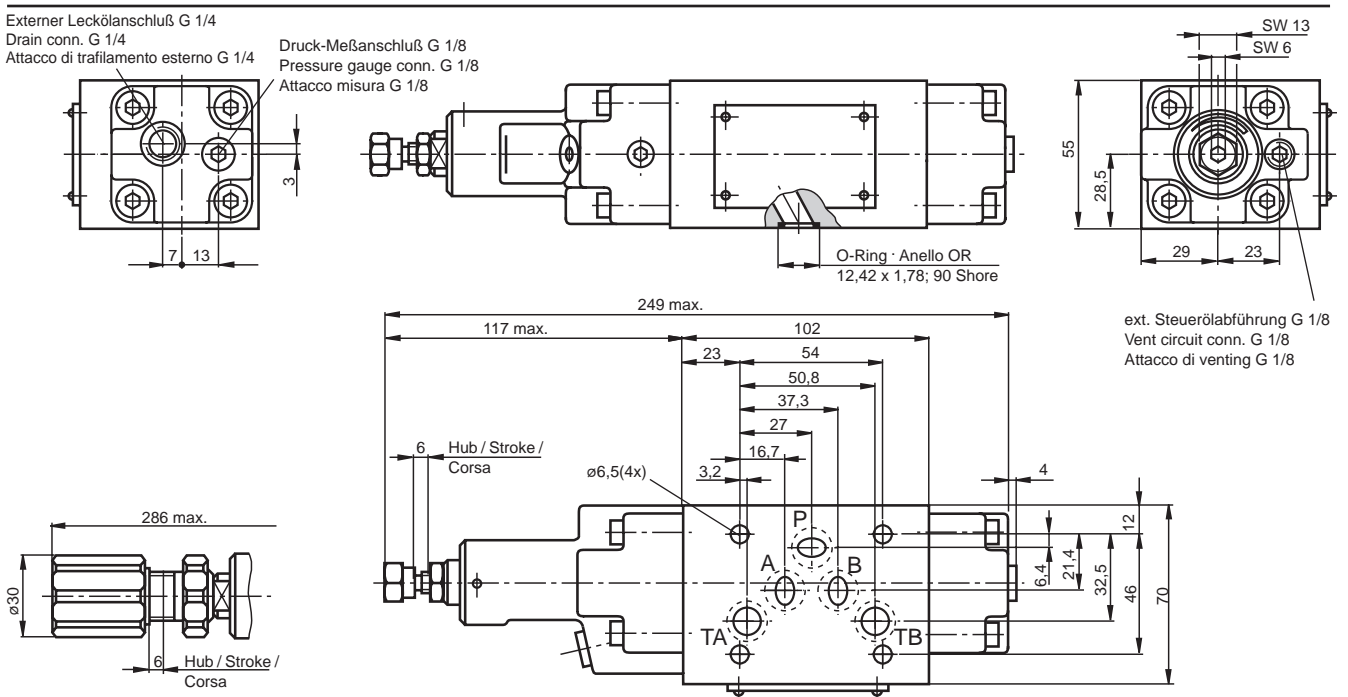

Bild / Fig. 1

Sinnbilder · Symbols · Simboli

	Zuschaltung in P Sequence in P sequenza in P		
--	--	--	--

Bild / Fig. 2

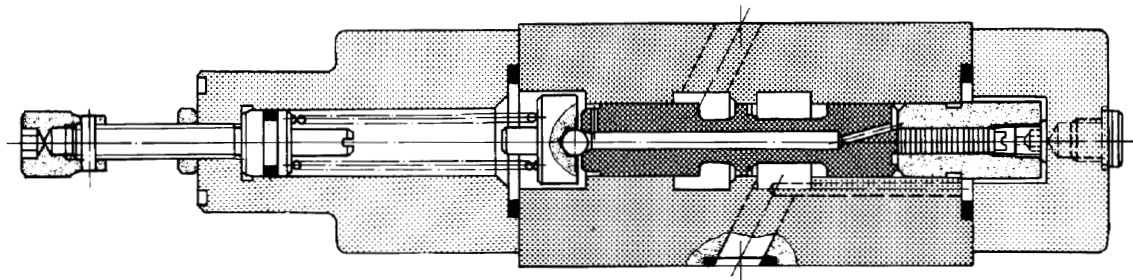
Kenngößen · Operating data · Dati caratteristici

Druckeinstellbereich Pressure adjustment range Campo di regolazione press.	siehe Typenschlüssel see model code vedi chiave di ordinazione	Gewicht Weight Peso	3,9 kg
Max. Betriebsdruck Max. operating pressure Press. di funzionamento max.	350 bar		
Max. Durchfluß Max. flow rate Portata max.	80 L/min		

Typenschlüssel · Model code · Chiave di ordinazione

J - M Q - 0 3 P - 2 * - 4 0	
Baureihe Series = J-MQ Serie	Ausführungskennzeichen (Stand bei Druck) Design Number (release on print date) N° del tipo (alla presente edizione) = 40
Baugröße NG 10 = 03 Size CETOP 5 Grandezza	Druckeinstellbereich Pressure adjustment range Campo di regolazione pressione 2,5 bar - 8,5 bar = 2A 5 bar - 35 bar = 2C 20 bar - 140 bar = 2E
Zuschaltung Sequence Sequenza in P = P	

Zwischenplattenventil, NG 10
Multi-stack valve, size 5
Valvola modulare, grandezza 5

Baureihe J-MQ
Series J-MQ
Serie J-MQ

Kennlinien · Characteristics · Curve caratteristiche

ermittelt bei $v = 32 \text{ mm}^2/\text{s}$ · determined $v = 32 \text{ mm}^2/\text{s}$ · rilevate $v = 32 \text{ mm}^2/\text{s}$



Bild / Fig. 3

Geräteabmessungen · Installation dimensions · Dimensioni

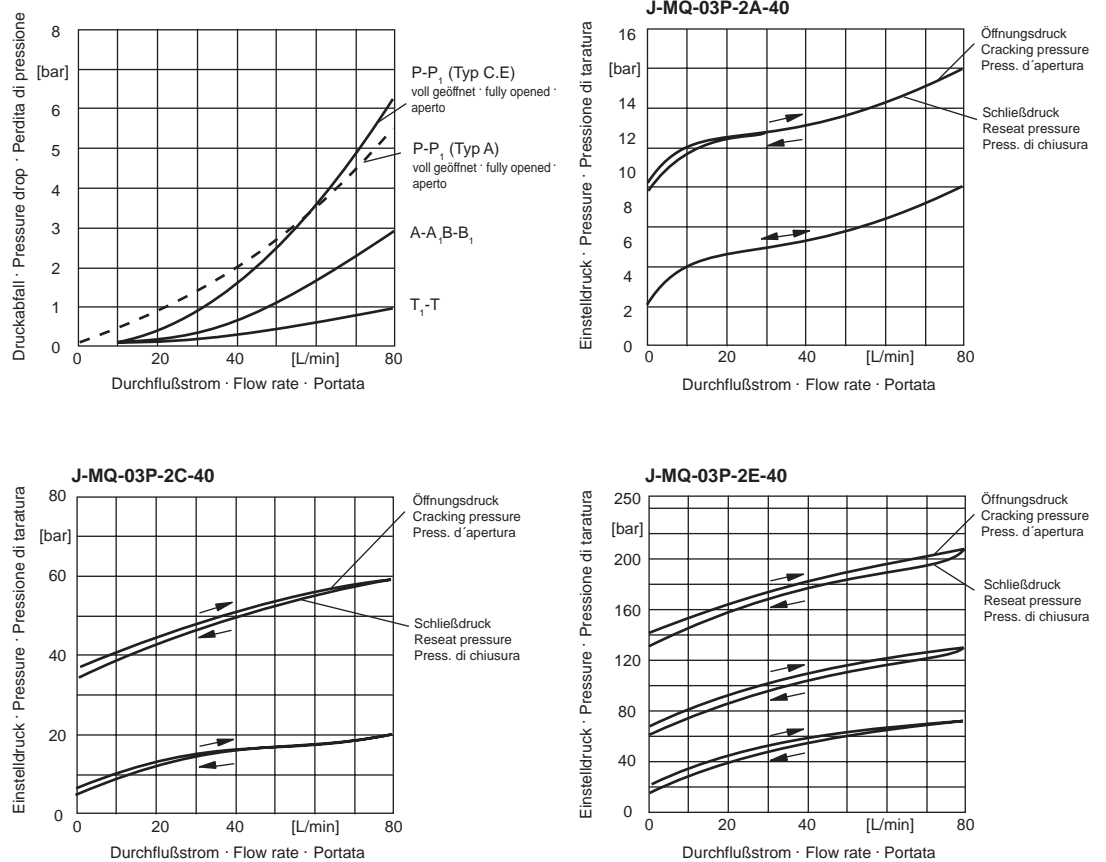

Bild / Fig. 4

Zwischenplattenventil, NG 10
Multi-stack valve, size 5
Valvola modulare, grandezza 5

Baureihe J-MQ
Series J-MQ
Serie J-MQ

Vorspannventil mit Umgehungs-Rückschlagventil · Counter balance valve with free flow return check valve · Valvola di bilanciamento con ritegno

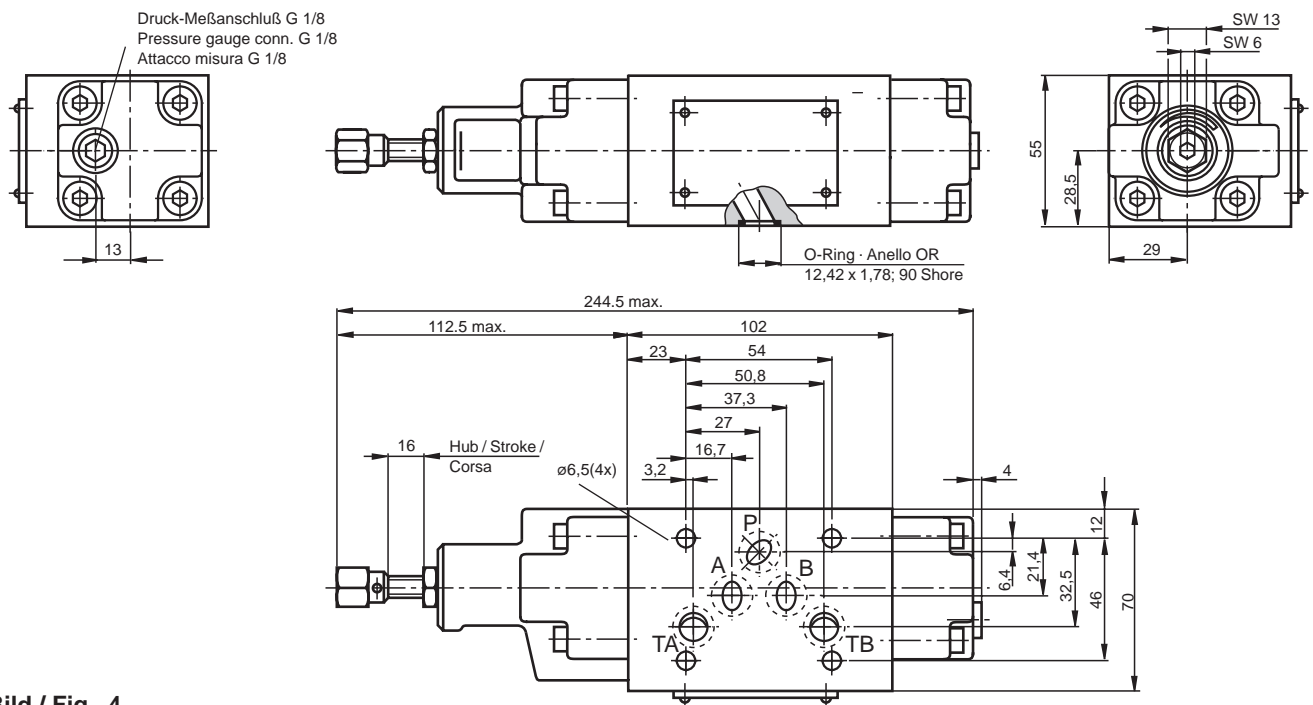

Bild / Fig. 1

Sinnbilder · Symbols · Simboli

	<p>Vorspannung in B Prestressing in B Pre-serraggio in B</p>		
--	--	--	--

Bild / Fig. 2

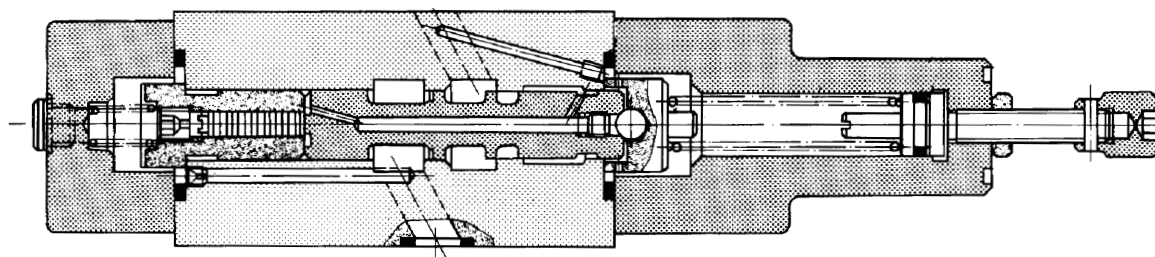
Kenngößen · Operating data · Dati caratteristici

<p>Druckeinstellbereich Pressure adjustment range Campo di regolazione press.</p>	<p>siehe Typenschlüssel see model code vedi chiave di ordinazione</p>	<p>Gewicht Weight Peso</p>	<p>3,9 kg</p>
<p>Max. Betriebsdruck Max. operating pressure Press. di funzionamento max.</p>	<p>350 bar</p>	<p>Öffnungsdruck-Rückschlagventil · Cracking pressure check valve · Press. d'apertura valvola di non ritorno</p>	<p>0,5 bar</p>
<p>Max. Durchfluß Max. flow rate Portata max.</p>	<p>80 L/min</p>		

Typenschlüssel · Model code · Chiave di ordinazione

<p>J - M Q - 0 3 B - 1 * - 4 0</p>		
<p>Baureihe Series Serie</p>	<p>= J-MQ</p>	<p>Ausführungskennzeichen (Stand bei Druck) Design Number (release on print date) N° del tipo (alla presente edizione)</p> <p>= 40</p>
<p>Baugröße NG 10 = 03 Size CETOP 5 Grandezza</p>		<p>Druckeinstellbereich Pressure adjustment range Campo di regolazione pressione</p> <p>2,5 bar - 8,5 bar = 1A 5 bar - 35 bar = 1C 20 bar - 140 bar = 1E</p>
<p>Vorspannung Prestressing Pre-serraggio</p> <p>in B = B</p>		

Zwischenplattenventil, NG 10
Multi-stack valve, size 5
Valvola modulare, grandezza 5

Baureihe J-MQ
Series J-MQ
Serie J-MQ

Kennlinien · Characteristics · Curve caratteristiche

ermittelt bei $v = 32 \text{ mm}^2/\text{s}$ · determined $v = 32 \text{ mm}^2/\text{s}$ · rilevate $v = 32 \text{ mm}^2/\text{s}$



Bild / Fig. 3

Geräteabmessungen · Installation dimensions · Dimensioni

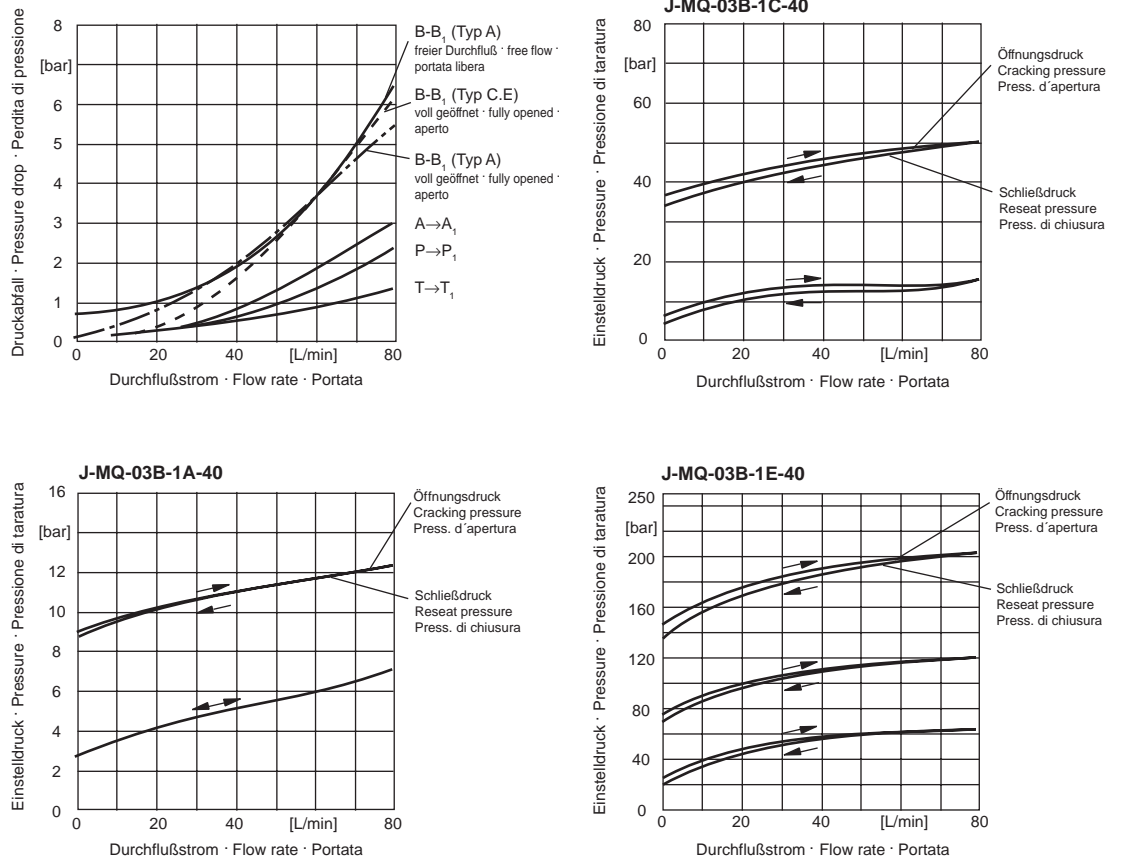

Bild / Fig. 4

Zwischenplattenventil, NG 10
Multi-stack valve, size 5
Valvola modulare, grandezza 5

Baureihe J-MT
Series J-MT
Serie J-MT

Drosselventil · Throttle valve · Strozzatore

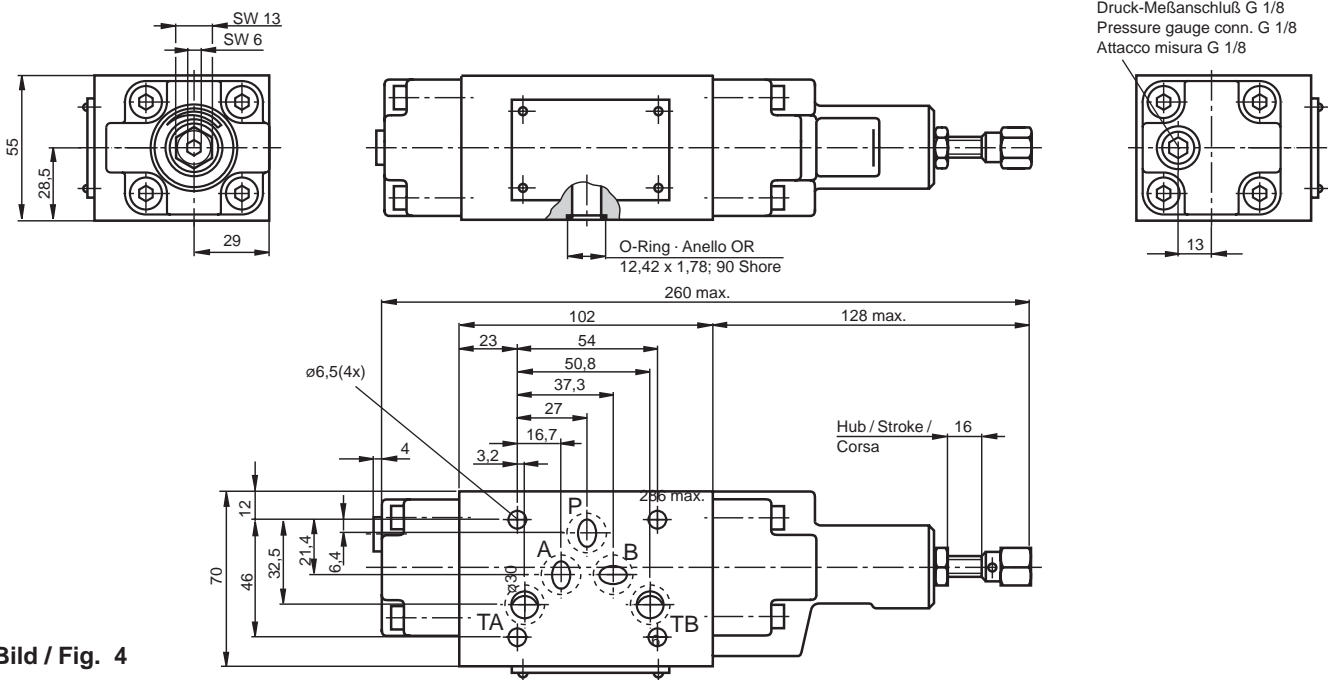

Bild / Fig. 1

Sinnbilder · Symbols · Simboli

	Drosselung in P Flow control in P Regolazione in P		
--	--	--	--

Bild / Fig. 2

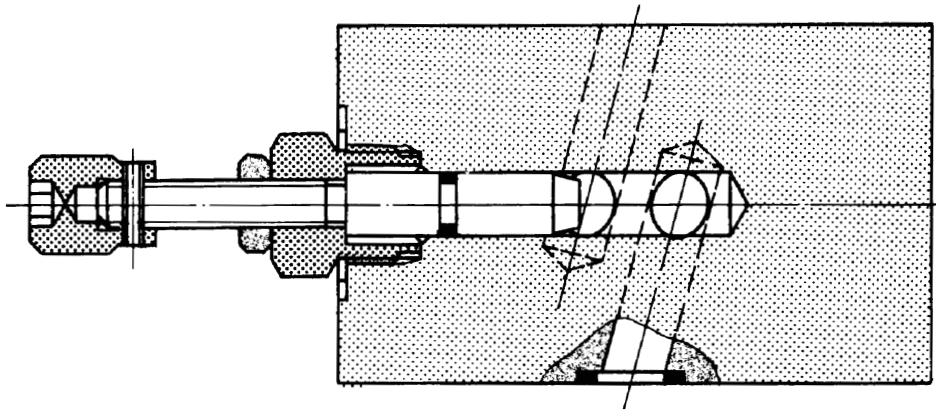
Kenngößen · Operating data · Dati caratteristici

Druckeinstellbereich Pressure adjustment range Campo di regolazione press.	siehe Typenschlüssel see model code vedi chiave di ordinazione	Gewicht Weight Peso	2,3 kg 2,3 kg mit Handrad with handwheel con volantino
Max. Betriebsdruck Max. operating pressure Press. di funzionamento max.	350 bar		
Max. Durchfluß Max. flow rate Portata max.	80 L/min		

Verdrehen der Verstellspindel im Uhrzeigersinn ist abnehmender Durchflußstrom. Verdrehen entgegen Uhrzeigersinn ist zunehmender Durchflußstrom.
 Clockwise rotation of the adjusting screw or handwheel decreases flow rate and counter-clockwise rotation increases it.
 La rotazione oraria della vite di regolazione o manopola riduce la portata e la rotazione anti-oraria la incrementa.

Typenschlüssel · Model code · Chiave di ordinazione

J - M T - 0 3 P - 4 0 - T		
Baureihe Series Serie = J-MT		Verstellung mit Werkzeug = ohne Angabe mit Handrad = T Adjustment with tool = without instruction with handwheel = T Registrazione con utensile = senza specifica con volantino = T
Baugröße NG 10 = 03 Size CETOP 5 Grandezza		
Drosselung Flow control Regolazione portata in P = P		Ausführungskennzeichen (Stand bei Druck) Design Number (release on print date) N° del tipo (alla presente edizione) = 40

Zwischenplattenventil, NG 10
Multi-stack valve, size 5
Valvola modulare, grandezza 5

Baureihe J-MT
Series J-MT
Serie J-MT

Kennlinien · Characteristics · Curve caratteristiche

ermittelt bei $v = 32 \text{ mm}^2/\text{s}$ · determined $v = 32 \text{ mm}^2/\text{s}$ · rilevate $v = 32 \text{ mm}^2/\text{s}$



Bild / Fig. 3

Geräteabmessungen · Installation dimensions · Dimensioni

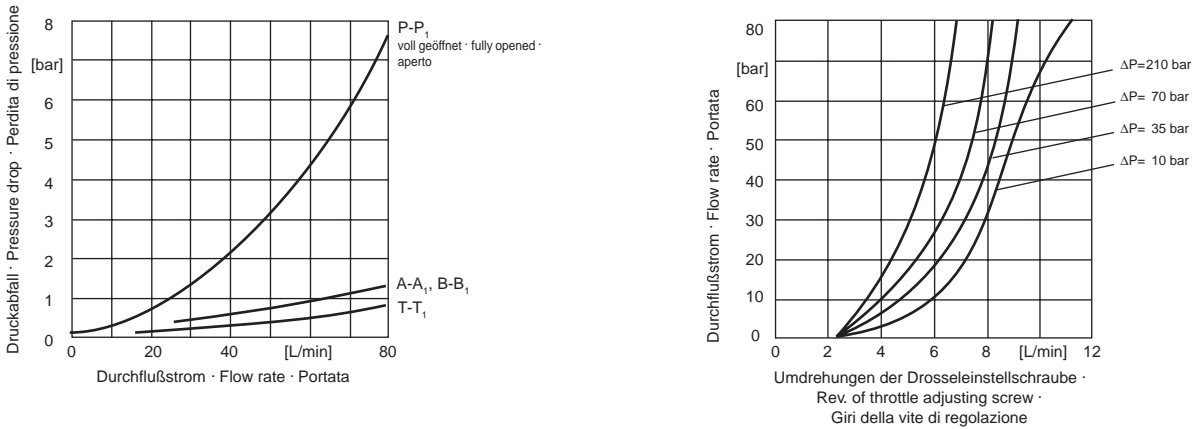

Bild / Fig. 4

Zwischenplattenventil, NG 10
Multi-stack valve, size 5
Valvola modulare, grandezza 5

Baureihe J-MT
Series J-MT
Serie J-MT

Drosselventil mit Umgehungsrückschlagventil · Throttle valve with free flow return check valve ·
Strozzatore con ritegno direzionale

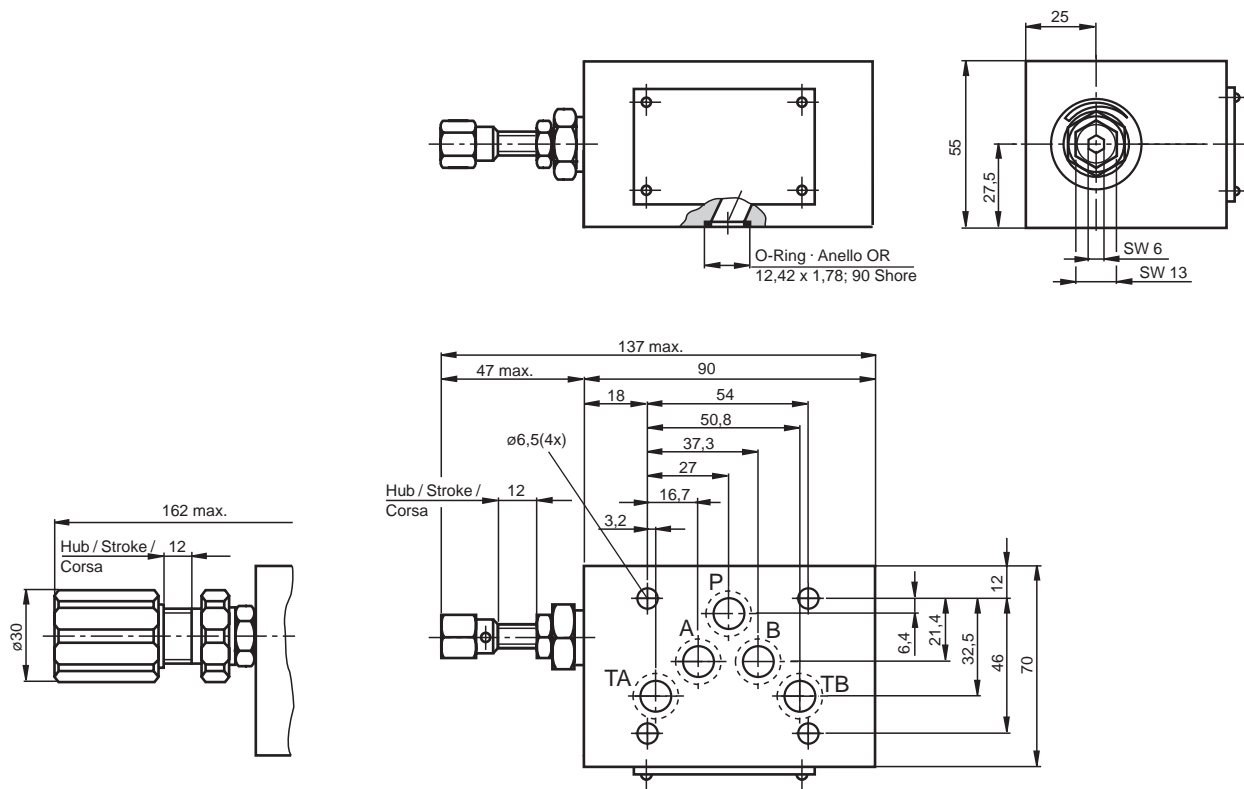

Bild / Fig. 1

Sinnbilder · Symbols · Simboli

 <p>P₁ T₁ A₁ B₁ W P T A B</p>	<p>Ablaufdrosselung Meter-out flow control Regolazione in uscita</p>	 <p>P₁ T₁ A₁ B₁ WI P T A B</p>	<p>Zulaufdrosselung Meter-in flow control Regolazione in entrata</p>
---	--	---	--

Bild / Fig. 2

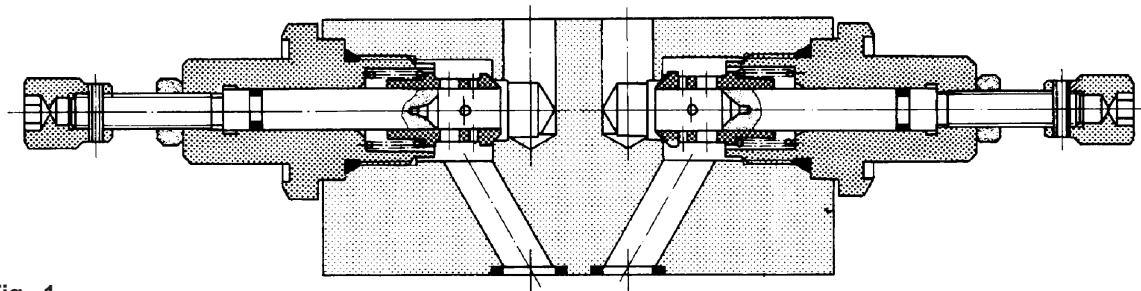
Kenngößen · Operating data · Dati caratteristici

Druckeinstellbereich Pressure adjustment range Campo di regolazione press.	siehe Typenschlüssel see model code vedi chiave di ordinazione	Gewicht Weight Peso	3,1 kg 3,1 kg mit Handrad with handwheel con volantino
Max. Betriebsdruck Max. operating pressure Press. di funzionamento max.	350 bar	Öffnungsdruck-Rückschlagventil · Cracking pressure check valve · Press. d'apertura valvola di non ritorno	1 bar
Max. Durchfluß Max. flow rate Portata max.	80 L/min		

Verdrehen der Verstellspindel im Uhrzeigersinn ist abnehmender Durchflußstrom. Verdrehen entgegen Uhrzeigersinn ist zunehmender Durchflußstrom.
 Clockwise rotation of the adjusting screw or handwheel decreases flow rate and counter-clockwise rotation increases it.
 La rotazione oraria della vite di regolazione o manopola riduce la portata e la rotazione anti-oraria la incrementa.

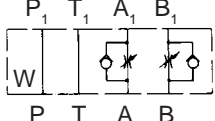
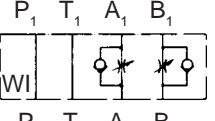
Typenschlüssel · Model code · Chiave di ordinazione

J - M T - 0 3 W * - 4 0 - T		
Baureihe Series = J-MT Serie		Verstellung mit Werkzeug = ohne Angabe mit Handrad = T Adjustment with tool = without instruction with handwheel = T Registrazione con utensile = senza specifica con volantino = T
Baugröße NG 10 = 03 Size CETOP 5 Grandezza		Ausführungskennzeichen (Stand bei Druck) Design Number (release on print date) N° del tipo (alla presente edizione) = 40
Drosselung Flow control Regolazione portata in A+B = W oder WI in A+B = W or WI à A+B = W ... WI		

Zwischenplattenventil, NG 10
Multi-stack valve, size 5
Valvola modulare, grandezza 5

Baureihe J-MT
Series J-MT
Serie J-MT

Kennlinien · Characteristics · Curve caratteristiche

ermittelt bei $v = 32 \text{ mm}^2/\text{s}$ · determined $v = 32 \text{ mm}^2/\text{s}$ · rilevate $v = 32 \text{ mm}^2/\text{s}$



Bild / Fig. 3

Geräteabmessungen · Installation dimensions · Dimensioni

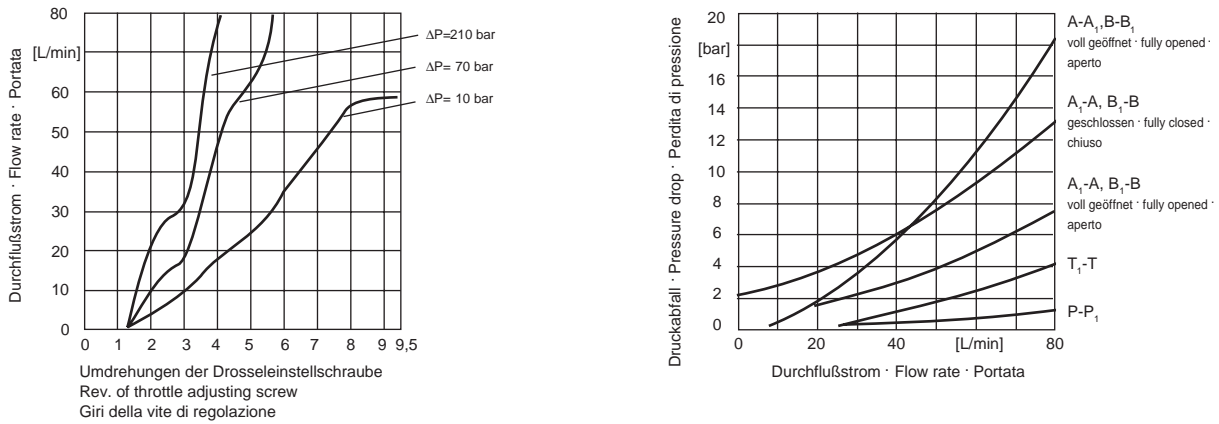

Bild / Fig. 4

Zwischenplattenventil, NG 10
Multi-stack valve, size 5
Valvola modulare, grandezza 5

Baureihe J-MC
Series J-MC
Serie J-MC

Rückschlagventil · Check valve · Ritegno

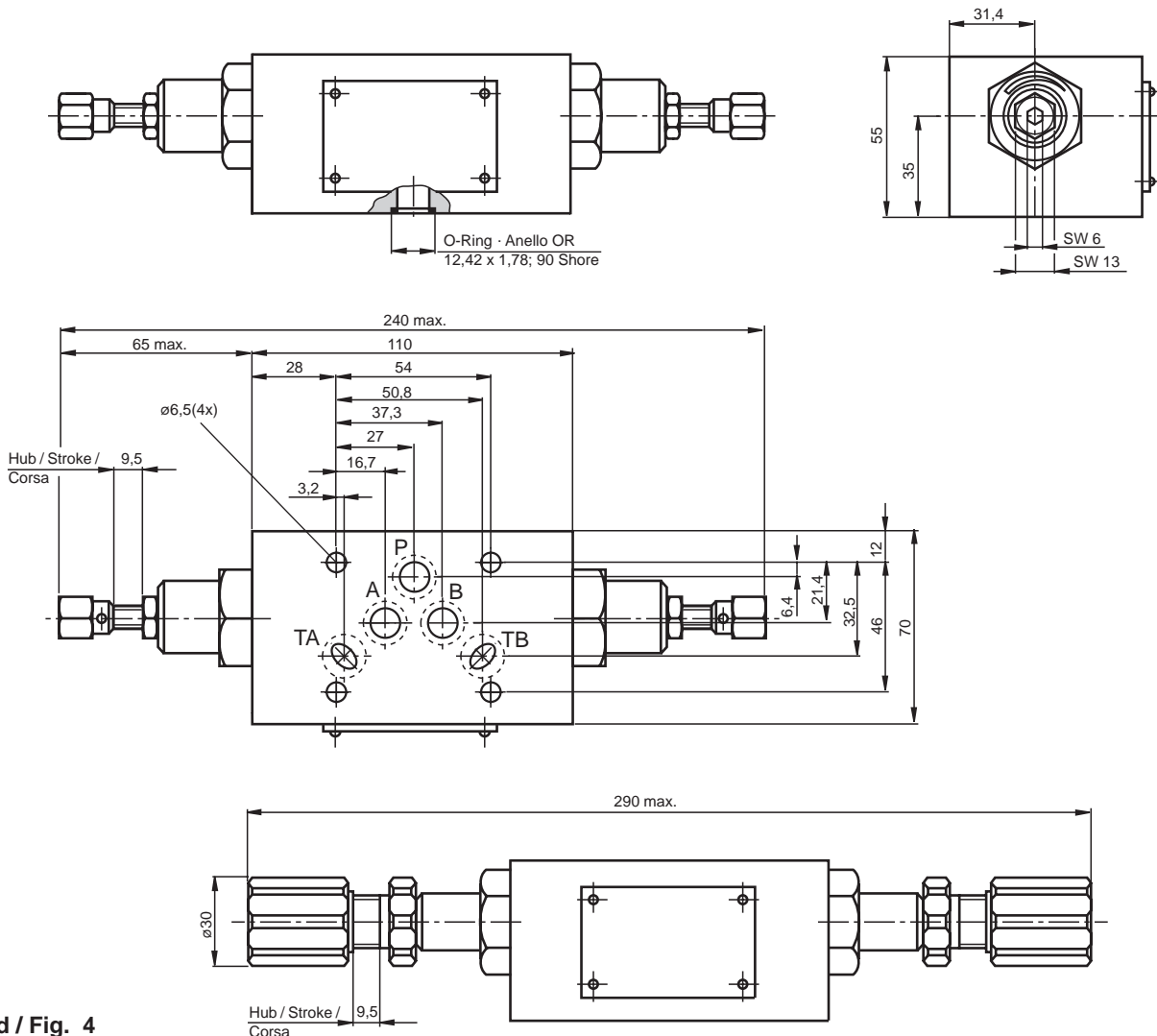

Bild / Fig. 1

Sinnbilder · Symbols · Simboli

	Gesperrt in P Blocking in P Blocco in P		Gesperrt in T Blocking in T Blocco in T
--	---	--	---

Bild / Fig. 2

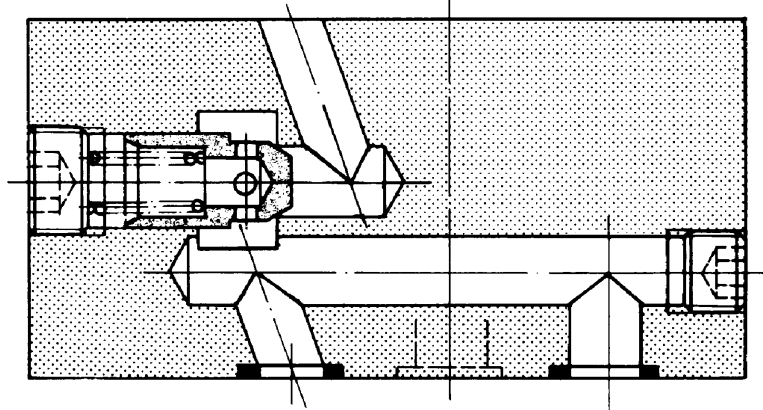
Kenngößen · Operating data · Dati caratteristici

Druckeinstellbereich Pressure adjustment range Campo di regolazione press.	siehe Typenschlüssel see model code vedi chiave di ordinazione	Gewicht Weight Peso	2,1 kg J-MC-03 P 2,9 kg J-MC-03 T
Max. Betriebsdruck Max. operating pressure Press. di funzionamento max.	350 bar		
Max. Durchfluß Max. flow rate Portata max.	80 L/min		

Typenschlüssel · Model code · Chiave di ordinazione

J - M C - 0 3 * - * 5 - 4 0			
Baureihe Series Serie	= J-MC	Ausführungskennzeichen (Stand bei Druck) Design Number (release on print date) N° del tipo (alla presente edizione)	= 40
Baugröße Size Grandezza	NG 10 = 03 CETOP 5	Öffnungsdruck Cracking pressure Press. d'apertura	0,5 bar = 05 4,5 bar = 45
Sperrung Blocking Blocco	in P = P in T = T		

Zwischenplattenventil, NG 10
Multi-stack valve, size 5
Valvola modulare, grandezza 5

Baureihe J-MC
Series J-MC
Serie J-MC

Kennlinien · Characteristics · Curve caratteristiche

ermittelt bei $v = 32 \text{ mm}^2/\text{s}$ · determined $v = 32 \text{ mm}^2/\text{s}$ · rilevate $v = 32 \text{ mm}^2/\text{s}$



Bild / Fig. 3

Geräteabmessungen · Installation dimensions · Dimensioni

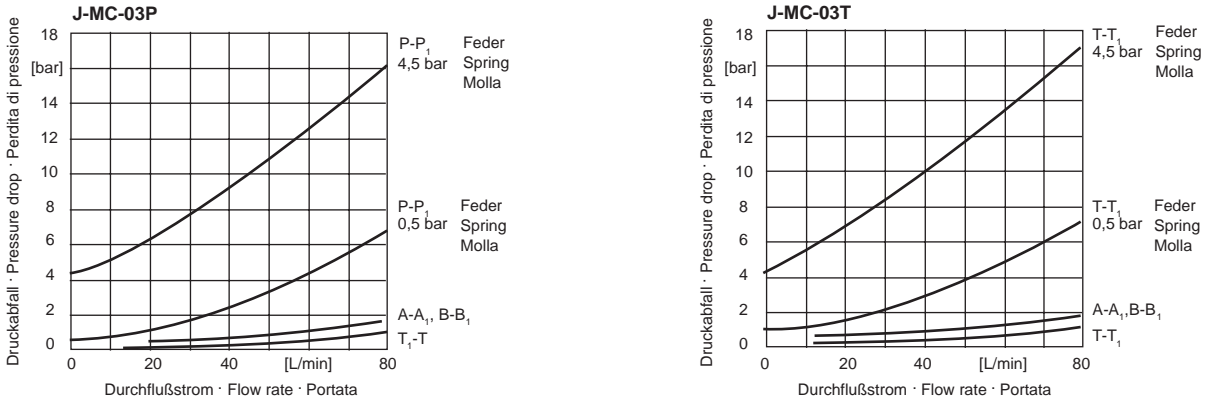

Bild / Fig. 4

Zwischenplattenventil, NG 10
Multi-stack valve, size 5
Valvola modulare, grandezza 5

Baureihe J-MP
Series J-MP
Serie J-MP

Rückschlagventil, hydr. entsperrbar, mit Vorentlastung · Pilot operated check valve with decompression · Valvola di non ritorno sbloccabile idraulic. con decompressione

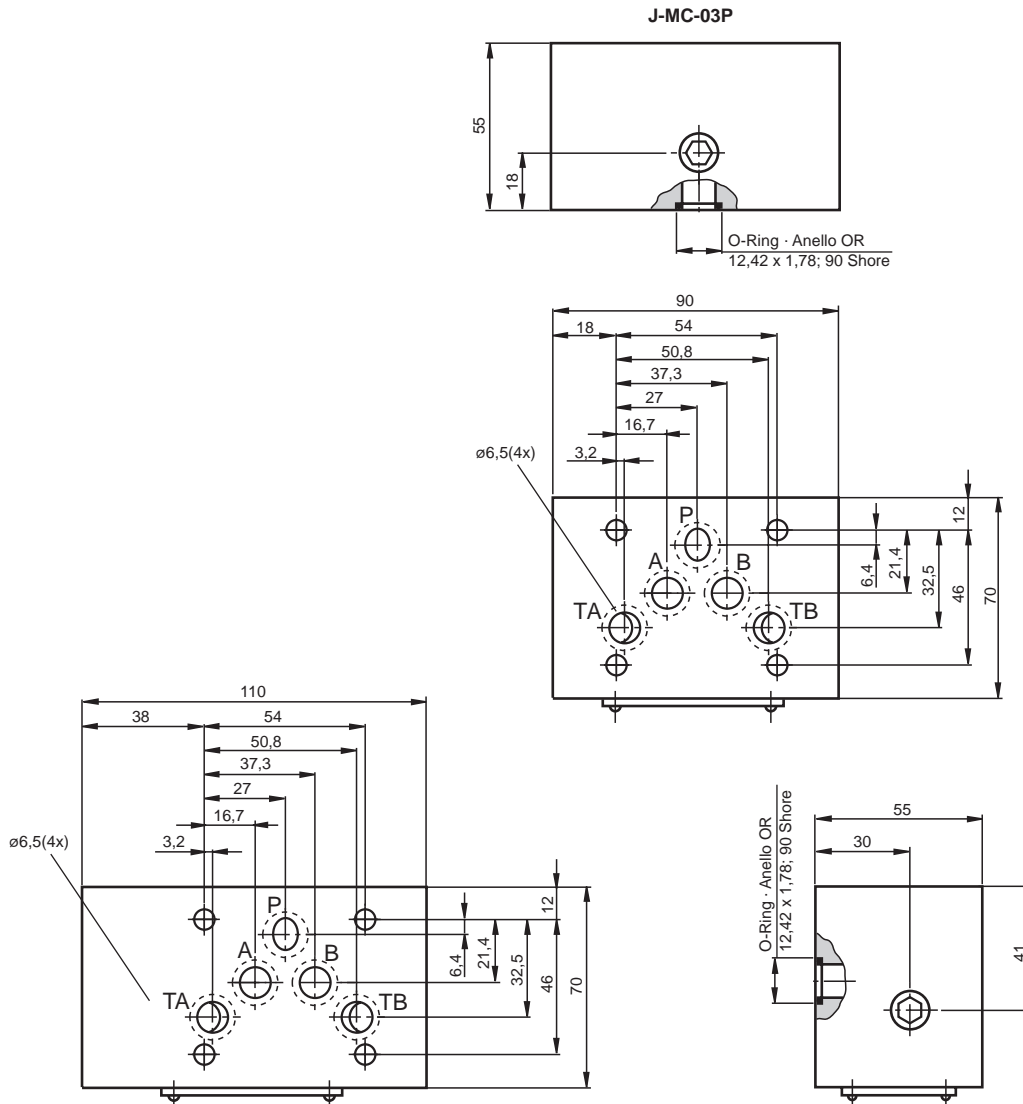

Bild / Fig. 1

Sinnbilder · Symbols · Simboli

			
Sperrung in · Blocking in · Blocco in B	Sperrung in · Blocking in · Blocco in A	Sperrung in · Blocking in · Blocco in A + B	

Bild / Fig. 2

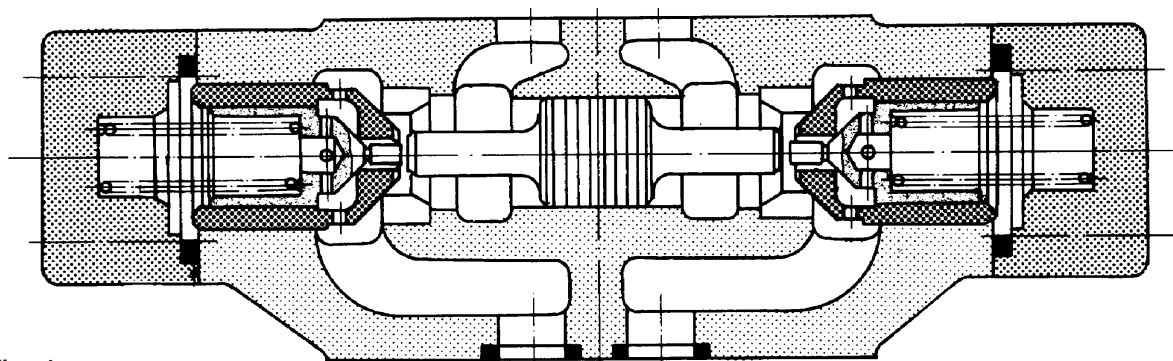
Kenngößen · Operating data · Dati caratteristici

Druckstellbereich Pressure adjustment range Campo di regolazione press.	siehe Typenschlüssel see model code vedi chiave di ordinazione	Gewicht Weight Peso	3,5 kg
Max. Betriebsdruck Max. operating pressure Press. di funzionamento max.	350 bar	Flächenverhältnis Steuerkolben zum Ventilsitz · Area of ratio · Rapporto aree tra pistone e sede	
Max. Durchfluß Max. flow rate Portata max.	80 L/min	a) Vorsteuerventil · Pilot valve · Valvola pilotata 13,7 : 1 b) Hauptventil · Main valve · Valvola principale 2,0 : 1	

Typenschlüssel · Model code · Chiave di ordinazione

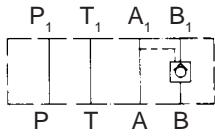
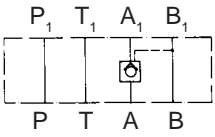
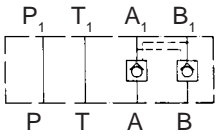
J - M P - 0 3 * - * 0 - 4 0

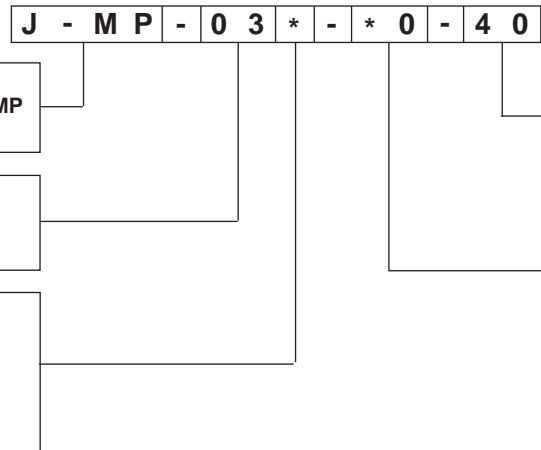
Baureihe Series Serie = J-MP		Ausführungskennzeichen (Stand bei Druck) Design Number (release on print date) N° del tipo (alla presente edizione) = 40
Baugröße NG 10 = 03 Size CETOP 5 Grandezza		Öffnungsdruck Cracking pressure Press. d'apertura 2 bar = 20 5 bar = 50
Sperrung Blocking Blocco in A = A in B = B in A+B = W		

Zwischenplattenventil, NG 10
Multi-stack valve, size 5
Valvola modulare, grandezza 5

Baureihe J-MP
Series J-MP
Serie J-MP

Kennlinien · Characteristics · Curve caratteristiche

ermittelt bei $v = 32 \text{ mm}^2/\text{s}$ · determined $v = 32 \text{ mm}^2/\text{s}$ · rilevate $v = 32 \text{ mm}^2/\text{s}$



Bild / Fig. 3

Geräteabmessungen · Installation dimensions · Dimensioni

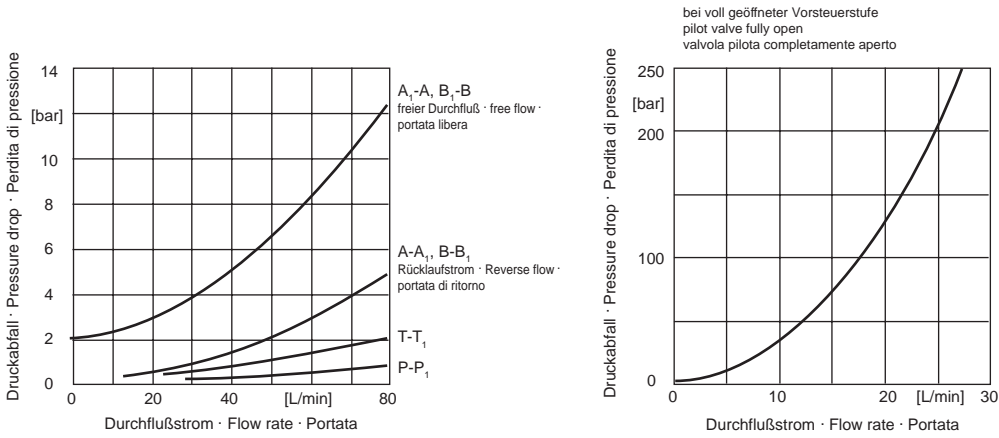

Bild / Fig. 4

Zwischenplattenventil, NG 10

Multi-stack valve, size 5

Valvola modulare, grandezza 5

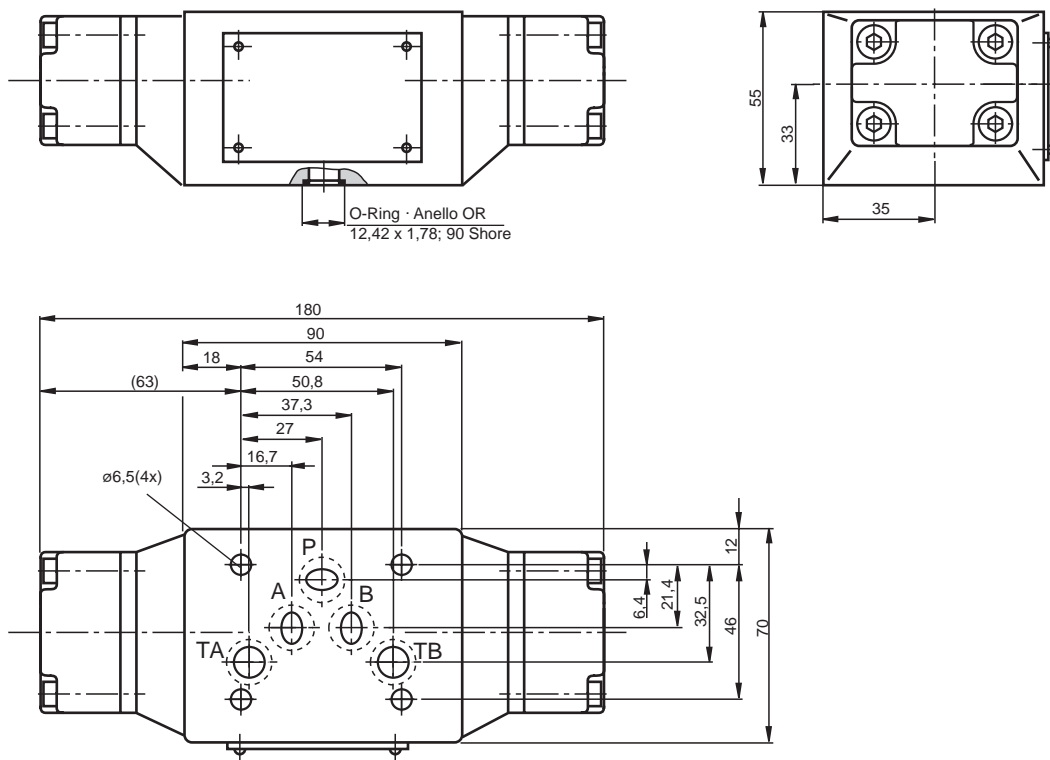
Zusatzplatten · Subplates · Piastre aggiuntive

Sinnbilder · Symbols · Simbolo



	Umlenkplatte Bypass block Piastra di adattamento		Abschlußplatte Cover block Piastra di chiusura
---	--	--	--

Bild / Fig. 1

Kenngößen · Operating data · Dati caratteristici

Max. Betriebsdruck Max. Operating pressure Press. di funzionamento max.	250 bar
Max. Durchflußstrom Max. Flow Portata max.	80 l/min

Typenschlüssel · Model code · Chiave di ordinazione

Umlenkplatte Bypass block Piastra di adattamento	Abschlußplatte Cover block Piastra di chiusura
J-BE-03-40	J-BS-03-40

Geräteabmessungen · Installation dimensions · Dimensioni



Bild / Fig. 2

Zwischenplattenventil, NG 10

Multi-stack valve, size 5

Valvola modulare, grandezza 5

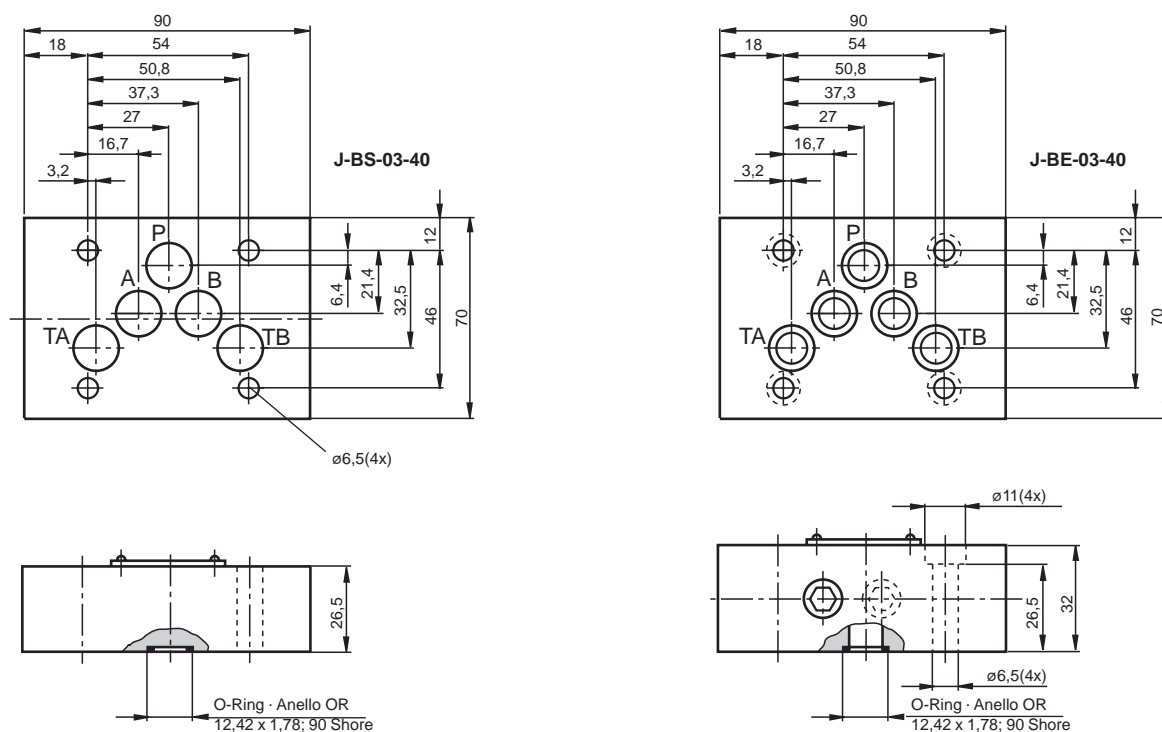
Reihenanschlußplatten · Manifold plates · Piastre multiple

Sinnbilder · Symbols · Simboli



Bild / Fig. 1

Kenngößen · Operating data · Dati caratteristici

Max. Betriebsdruck Max. Operating pressure Press. di funzionamento max.	250 bar
Max. Durchflußstrom Max. Flow Portata max.	80 l/min

Typenschlüssel · Model code · Chiave di ordinazione

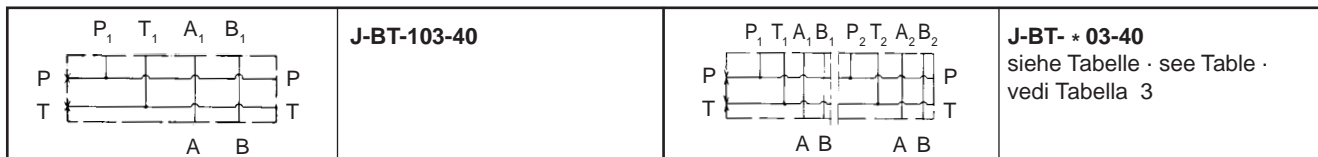
Typenschlüssel Model code Chiave di ordinazione	Anzahl der Stationen No. of Stations N.° di stazioni				Gewicht · Weight · Peso kg
		M	M1	L	
J-BT-103-40	1	0	0	110	8,0
J-BT-203-40	2	75	75	185	13,5
J-BT-303-40	3	150	150	260	19,5
J-BT-403-40	4	225	225	335	26,0
J-BT-503-40	5	300	300	410	31,5
J-BT-603-40	6	375	375	485	37,5

Größere Abmessungen auf Anfrage · Other dimensions on inquiry · Altre dimensioni a richiesta

Geräteabmessungen · Installation dimensions · Dimensioni



Bild / Fig. 2

Zwischenplattenventil, NG 10

Multi-stack valve, size 5

Valvola modulare, grandezza 5

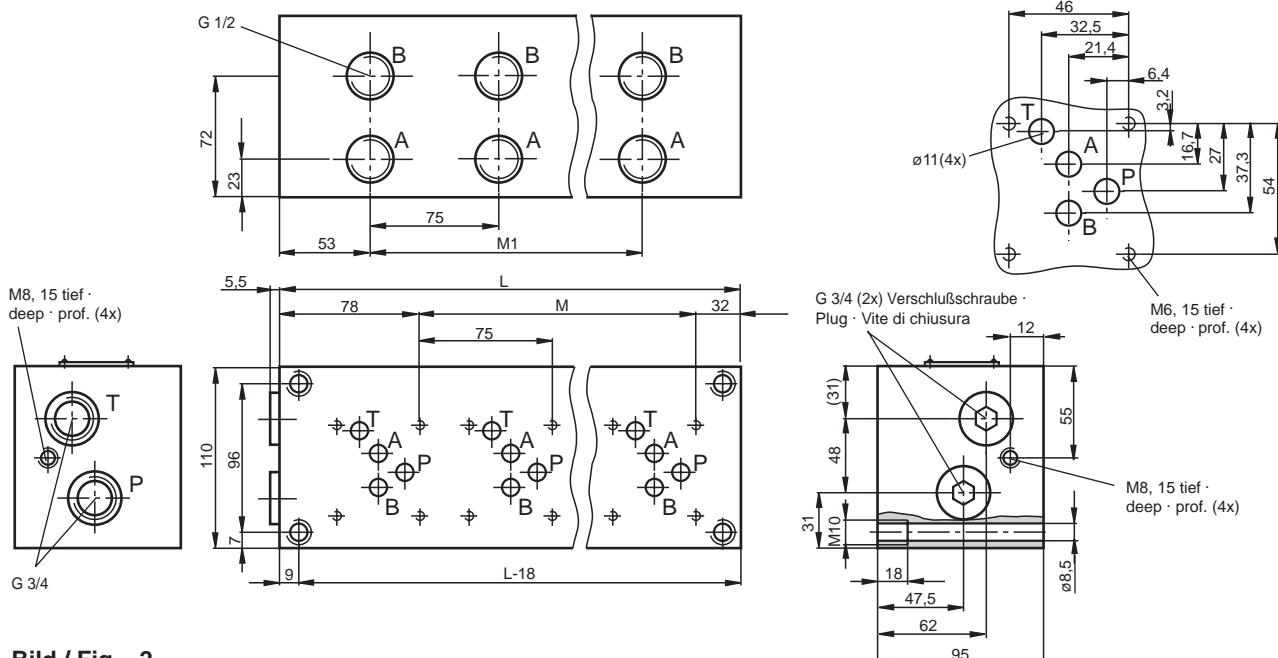
Zubehör · Accessories · Accessori

Innensechskantschraube Socket head bolt Vite a esagono interno			Gewindebolzen Stud bolt Bullone		
Benennung Name Descrizione	Bestell-Nr. Part-No. No. d'ordinaz.	l_H	Benennung Name Descrizione	Bestell-Nr. Part-No. No. d'ordinaz.	
M6 x 35 DIN 912 - 10.9	508 994	0	M6 x 50 - 10.9	743 799	
M6 x 95 DIN 912 - 10.9	742 411	55	M6 x 105 - 10.9	743 807	
M6 x 150 DIN 912 - 10.9	743 765	110	M6 x 160 - 10.9	743 815	
M6 x 205 DIN 912 - 10.9	743 773	165	M6 x 215 - 10.9	743 823	
M6 x 260 DIN 912 - 10.9	743 781	220	M6 x 270 - 10.9	743 831	

Bild / Fig. 1



Befestigungsschrauben: Ein Satz besteht aus 4 Stück
 Mounting bolts: 4 bolts are included as a set
 Viti di fissaggio: Un set consta di 4 pezzi

Gewindebolzen: In einem Satz sind 4 Gewindebolzen enthalten, Studnuten extra bestellen
 Stud bolts: In a set are 4 stud bolts included, please order stud nut separatly
 Bulloni: In un set sono compresi 4 bulloni dadi, si prega di ordinare dadi a testa separatamente

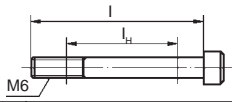
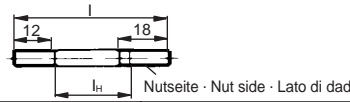
Anzugsmoment: 11 Nm bis 15 Nm
 Tightening torque: 11 Nm up to 15 Nm
 Coppia di serraggio: 11 Nm fino a 15 Nm

Techn. Änderungen vorbehalten
 Subject to technical changes
 Soggetto a variazioni senza preavviso

Zwischenplattenventil, NG 6 und 10
Multi-stack valve, size 3 and 5
Valvola modulare, grandezza 3 e 5

Notizen · Notes · Appunti

Lieferprogramm

SAUER BIBUS liefert ein komplettes Programm an Hydraulikkomponenten, von Regelpumpen im offenen Kreislauf über Ventile bis hin zu kompletten hydrostatischen Antriebssystemen und Steuerungen für den Stationär- und Mobilmarkt.

SAUER BIBUS bietet Kunden und zukünftigen Kunden erfahrungsorientierte Ingenieurleistung von der Projektstudie bis zu Serienfertigung. Wir beraten Sie und lassen Sie von unseren Erfahrungen aus vielen Anwendungsfällen profitieren.

Sales Program

SAUER BIBUS furnishes a complete program of hydraulic components from valves and open circuit variable displacement pumps right up to complete hydrostatic drive systems and controls for stationary and mobile market.

SAUER BIBUS offers present and future customers engineering services based on sound experience, from project studies to serial production. We shall be glad to advise you and enable you to profit from our store of experience gained from countless applications.

Programma di vendita

La **SAUER BIBUS** è in grado di fornire un programma completo di componenti idraulici, dalle valvole e pompe in circuito aperto a cilindrata variabile fino ai controlli e ai sistemi completi per l'azionamento idrostatico per i mercati del Mobile e dell' Industriale.

La **SAUER BIBUS** offre ai clienti attuali e futuri un servizio tecnico basato su una solida esperienza, dalla progettazione alla produzione di serie. Saremo lieti di consigliarvi e di farvi trarre profitto dal nostro bagaglio di esperienza acquisito in innumerevoli applicazioni.



SAUER BIBUS Service weltweit ...

Der weltweite Fertigungs- und Entwicklungsverbund SAUER SUNDSTRAND für Europa, Afrika und den Nahen Osten. SUNDSTRAND SAUER in den USA für die amerikanische Hemisphäre und DAIKIN in Japan für den ostasiatischen Raum, ermöglicht es SAUER BIBUS, in fast allen Ländern der Welt Service zu bieten.

SAUER BIBUS Service worldwide ...

Thanks to the worldwide manufacturing and development cooperation between SAUER SUNDSTRAND for Europe, Africa and the Near East, SUNDSTRAND SAUER in the US for the American hemisphere and DAIKIN in Japan for the Far East. SAUER BIBUS is able to offer service facilities in almost every country in the world.

Assistenza SAUER BIBUS nel mondo ...

Grazie agli stabilimenti produttivi sparsi nel mondo e alla cooperazione nella ricerca tra SAUER SUNDSTRAND per l'Europa, Africa e Medio Oriente, SUNDSTRAND SAUER negli USA per l'emisfero Americano e DAIKIN in Giappone per l'estremo oriente, la SAUER BIBUS è in grado di offrire un servizio assistenza in quasi tutti i paesi del mondo.

Druckfehler, Irrtümer und Technische Änderungen vorbehalten

Misprint, errors and contents subject to technical changes

Questo testo è valido salvo errori di stampa e sviste ed è soggetto a cambiamenti tecnici.



Sauer Bibus GmbH
Im Riedle 10
D-89278 Nersingen
Telefon: (07308) 9660-0
Telefax: (07308) 9660-10
e-mail SAUER_BIBUS@T-ONLINE.DE



Via Bonazzi 19/21
40013 Castel Maggiore - BO
Tel.: (051) 70.17.45 - 70.16.89
Telefax: (051) 701386
Telex: 511287 Turbo I