

Wegeventil, NG 10

Directional Control Valve, Size 5

Valvola Distributrice, grandezza 5



Wegeventil, NG 10
Directional control valve, size 5
Valvola distributrice, grandezza 5

Baureihe J-KSO
Series J-KSO
Serie J-KSO



Bild 1
Fig. 1

Besondere Merkmale:

- Anschlußbild nach DIN, ISO, CETOP
- Gerätestecker nach DIN, ISO
- hohe Schaltsicherheit
- lange Lebensdauer
- strömungstechnisch optimiert für hohen Durchfluß
- druckdichte Hubmagnete für Gleich- und Wechselspannung
- Hubmagnete mit Notbetätigung

Special characteristics:

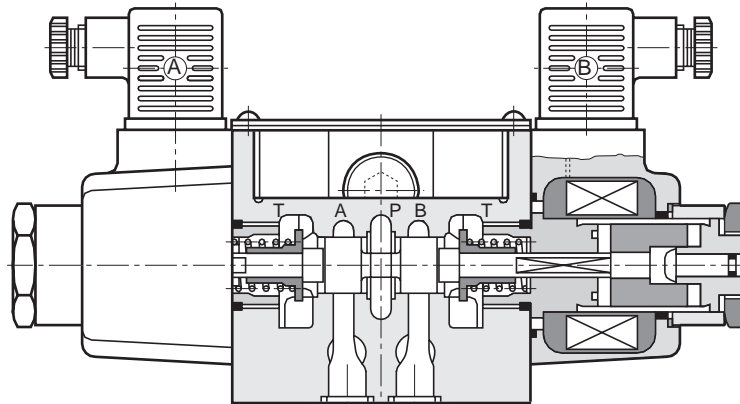
- connection bore diagram according to DIN, ISO, CETOP
- power plug according to DIN, ISO
- high switching safety
- high durability
- optimum flow technology for high flow capacity
- pressure-tight solenoids for direct current and alternating current
- solenoids with emergency manual override

Caratteristiche speciali:

- diagramma di connessione secondo DIN, ISO, CETOP
- connettore secondo DIN, ISO
- grande sicurezza di manovra
- elevata durata di vita
- tecnica dei fluidi ottimale per grande portata
- bobine stagne per tensione continua ed alternata
- bobine con comando manuale d'emergenza

Typenschlüssel · Model Code · Codice dei modelli

J - KSO - G03 - * * * * - 20 - * *

Baureihe
Series
Serie
 = J-KSO

Mit Standard-Steckverbindung DIN 43650 und ISO 4400
 weitere elektr. Anschlüsse auf Anfrage
 with standard plug connection DIN 43650 and ISO 4400
 other connections on request
 con connessioni solenoide standard DIN 43650 e ISO 4400
 altre connessioni a richiesta

Befestigungsart
Type of attachment
Fissaggio
 Anschlußplattenmontage = G
 Gasket mounting
 Montaggio su piastra di raccordo

Baugröße NG 10
Size CETOP 5 = 03
Grandezza

Kolbentyp / Kolbenrückstellung
Spool type / spool function
Tipo di pistone / richiamo pistone
 siehe Tabelle 2
 see table 2
 vedi tabella 2

Sonderausführung
Special type
Esecuzione speciale
 siehe Tabelle 2
 (andere Ausführungen auf Anfrage)
 see table 2
 (other spool types on inquiry)
 vedi tabella 2
 (altri modelli su richiesta)

Ausführungskennzeichen (Stand bei Druck)
Design Number (release on print date)
N° del tipo (alla presente edizione)
 = 20

Magnetspannung
Solenoid ratings
Tensione della bobina
 AC 110 V (50 Hz); AC 120 V (60 Hz) = C
 AC 220 V (50 Hz); AC 240 V (60 Hz) = D
 DC 12 V = N
 DC 24 V = P

Weitere Spannungen auf Anfrage
 Other voltages on request
 Altri voltaggi a richiesta

Wegeventil, NG 10
Directional control valve, size 5
Valvola distributrice, grandezza 5

Baureihe J-KSO
Series J-KSO
Serie J-KSO

Kenngößen · Operating Data · Caratteristiche

Tabelle 1 / Table 1 / Tabella 1

Allgemeine Kenngößen · General Operating Data · Caratteristiche generali		
Benennung Description Designazione	-	4/2- und 4/3- Wegeventil 4/2- and 4/3- directional control valve valvola distributrice 4/2 e 4/3 vie
Bauart Construction Costruzione	-	Kolbenschieber Spool valve Valvola a pistone
Befestigungsart Type of attachment Tipo di fissaggio	-	Anschlußlochbild nach DIN 24340 Form A, ISO 4401 und CETOP R 35 H Connection bore diagram acc. to DIN 24340 form A, ISO 4401 and CETOP R 35 H Piano di foratura secondo disegno DIN 24340 forma A, ISO 4401 e CETOP R 35 H
Anschlußgröße Size Grandezza	-	NG 10 CETOP 5
Einbaulage Mounting position Posizione di montaggio	-	beliebig (waagrecht bei Typ ohne Federrückstellung) any (horizontal for type without spring off-set) a scelta (orizzontale per modelli senza molla di richiamo)
Dichtungsausführung Kind of seal Guarnizioni	-	Perbunan, Viton auf Anfrage Perbunan, Viton on request Perbunan, Viton a richiesta
Umgebungstemperatur Ambient temperature range Temperatura ambiente	°C	-15 ... +50
Relative Luftfeuchtigkeit Relative humidity Umidità relativa dell'aria	%	0 ... 95
Hydraulische Kenngößen · Hydraulic Operating Data · Caratteristiche idrauliche		
Max. Betriebsdruck Max. operating pressure Pressione massima di servizio	bar	350 bitte Hinweise Tabelle 2 beachten please note table 2 osservare indicazione tabella 2
Max. Rücklaufdruck (Anschluß T) Max. return line pressure (port T) Press. mass. di ritorno (raccorco T)	bar	175 (4-Wege-Funktion / 4-Way-function / funzione 4 vie)
Druckmitteltemperatur Hydraulic fluid temperature Temperatura del fluido	°C	-15 ... +70
Viskositätsbereich Viscosity range Gamma di viscosità	mm ² /s	15 ... 400 max. 800 * * kurzzeitig bei Kaltstart, wenige Sekunden intermittend cool start, only seconds intermittente a freddo, pochi secondi
Max. Durchfluß Max. flow rate Portata massima	L/min	160 (DC) (siehe Tabelle 2 / see table 2 / vedi tabella 2) 130 (AC)
Empfohlene Druckflüssigkeit Pressure medium requirements Fluido raccomandato	-	ISO VG 32, 46, 68 auf Mineralölbasis nach DIN 51524 und DIN 51525 ** Basic on mineral oil to DIN 51524 and DIN 51525 ** a base minerale secondo DIN 51524 e DIN 51525 **
Empfohlene Filterfeinheit Filtration requirements Filtraggio raccomandato	µm	25 absolut / absolute / assoluto
Betätigungsart · Control · Comando		
Magnetbetätigt Solenoid Bobina	-	mit Nothandbetätigung am Magnet with emergency manual override con comando manuale d'emergenza

** andere Flüssigkeiten auf Anfrage · other fluid on request · altri fluidi a richiesta

Wegeventil, NG 10
Directional control valve, size 5
Valvola distributrice, grandezza 5

Baureihe J-KSO
Series J-KSO
Serie J-KSO

Kenngößen · Operating Data · Caratteristiche

Tabelle 1 / Table 1 / Tabella 1

Elektrische Kenngößen · Electrical Operating Data · Caratteristiche Elettriche			
Spannungsart Voltage Votaggio	-	Gleichstrom = (DC) Direct current = (DC) Corrente continua = (DC)	Wechselstrom ~ (AC) Alternating current ~ (AC) Corrente alternata ~ (AC)
Nennspannung Rated voltage Votaggio nominale	V	12, 24	110 V 50 Hz 120 V 60 Hz 220 V 50 Hz 240 V 60 Hz
Max. Leistungsaufnahme Max. Power consumption Potenza massima assorbita	W	38	$P_{A20} = 96, P_{H20} = 37^*$
Relative Einschaltdauer Relative duty cycle Durata relativa d'inserzione	%	100	
Elektrischer Anschluß Solenoid connection Connessioni solenoidi	-	Standard-Steckverbindung DIN 43650 und ISO 4400, Kabelverschraubung PG 11, Kabel- \varnothing 6-10mm Standard-plug DIN 43650 and ISO 4400, screw type conduit fitting PG 11, cable diameter 6-10mm Connetteri standard DIN 43650 e ISO 4400, avvitatura cavo PG 11, diametro cavo 6-10mm	
Schutzart nach DIN 40050 und IEC Degree of protection to DIN 40050 and IEC Grado di protezione secondo DIN 40050 ed IEC	-	IP 65	
Magnet Solenoid Bobina	-	druckdicht, in Öl geschaltet tight, inserted in oil stagna, immersa in olio	
Netzspannungstoleranz Voltage tolerance Tolleranza di tensione	%	± 10	
Isolationswiderstand Insulation Resistenza d'isolamento	M Ω	50	
Isolationsgruppe Insulation grade Classe d'isolamento	-	B (H für den Spulenkörper / H only for coil / H per il corpo della bobina)	
Durchschlagspannung Withstand voltage Tensione di perforazione	V	1500	
Schaltzeit · Response Time · Tempo di risposta			
Einschaltzeit / Energizing / Tempo d'inserzione Ausschaltzeit/De-energizing/Tempo di disinserzione Schalthäufigkeit Time on in percent Numero di manovre	s	0,03 - 0,09	0,005 - 0,025
	s	0,02 - 0,05	0,005 - 0,030
	n/min	240	60 bei Gleichrichter 240 60 at rectifier 60 con raddrizzatore
Gewicht · Weight · Peso			
Einfachmagnet Single solenoid Bobina semplice	kg	4,8	3,8
Doppelmagnet Double solenoid Bobina doppia	kg	6,1	4,8
Zubehör · Accessoires · Accessori Anschlußplatten, Befestigungsschrauben Connection plates, fixing bolts Piastre di raccordo, viti di fissaggio	-	siehe Seite 8, 10 und 11 see page 8, 10 and 11 vedi pagina 8, 10 ed 11	













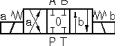

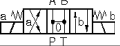

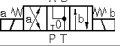

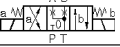
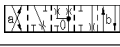

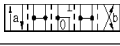

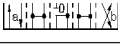

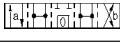
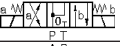
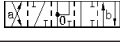
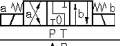

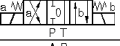
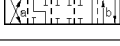
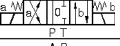

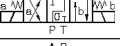
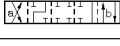

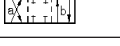
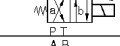
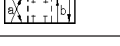
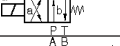

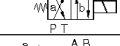

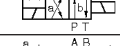
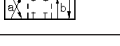
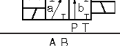
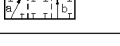
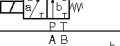
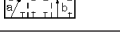
* P_{A20} = Einschaltleistung bei 20°C Magnettemperatur · Energizing power at 20°C solenoid temp. · Potenza d'inserzione con temperatura della bobina 20°C
 P_{H20} = Halteleistung bei 20°C Magnettemperatur · Withstand power at 20°C solenoid temp. · Potenza di tenuta con temperatura della bobina 20°C

Wegeventil, NG 10
Directional control valve, size 5
Valvola distributrice, grandezza 5

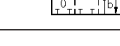
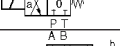
Baureihe J-KSO
Series J-KSO
Serie J-KSO

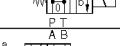
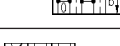
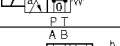
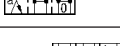
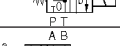
Ausführungsvarianten und Schaltzeichen (andere Varianten auf Anfrage)
Standard models and symbols (other variants on request)
Varianti d'eseecuzione e simboli (altri modelli su richiesta)

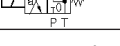
Tabelle 2 / Table 2 / Tabella 2

Kolbentyp / Kolbenrückstellung Spool type / Function Tipo di pistone / richiamo pistone	Ausführungskennzeichen Design-no. Numero del tipo	Sonderausführung Special type Esecuzione speciale	Sinnbild Symbol Simbolo	Schaltzeichen mit Übergangsstellung Symbol with transient response Simbolo con posizione transitoria	Magnetspannung Powersupply Tensione d'alimentazione	Max. Durchfluß L/min Max. flow rate L/min Portata massima L/min (Seite 7, page 7, pagina 7)			Δp-Q Kennlinie Δp-Q characteristic Curva caratteristica Δp-Q (Seite 7, page 7, pagina 7)		
									P -> A P -> B	B -> T A -> T	P -> T
2 C	- 20				DC	A	a	a	3	3	-
					AC	C	k	k			
3 C	- 20				DC	A	A	A	2	4	4
					AC	C	C	C			
4 C	- 20				DC	F	a	a	3	3	-
					AC	H	k	k			
44 C	- 20				DC	F	a	a	3	3	-
					AC	H	k	k			
5 C	- 20				DC	A	A	c	2	2	4
					AC	C	C	n			
51 C	- 20				AC	A	c	A	4	6	4
					DC	C	n	C			
66 C	- 20	*			DC	G	h	h	5	7	7
					AC	I	t	t			
7 C	- 20				DC	A	f	f	2	3	-
					AC	C	r	r			
8 C	- 20				DC	F	a	a	3	3	-
					AC	H	k	k			
81 C	- 20				AC	F	a	a	3	3	-
					DC	H	k	k			
9 C	- 20				DC	A	g	b	2	3	-
					AC	C	q	p			
91 C	- 20				AC	A	b	g	2	3	-
					DC	C	p	q			
2 A	- 20				DC	D	b	e	3	3	-
					AC	D	a	m			
2 B	- 20				DC	D	e	b	3	3	-
					AC	D	m	a			
3 A	- 20				AC	C	C	A	2	1	-
					DC	C	C	C			
3 B	- 20				DC	C	C	A	2	1	-
					AC	C	C	C			
2 D	- 20				DC	E	i	i	3	3	-
					AC	E	s	s			
20 D	- 20				AC	-	i	i	3	-	-
					DC	-	s	s			
20 A	- 20				AC	-	e	b	3	-	-
					DC	-	l	a			
20 B	- 20				AC	-	b	e	3	-	-
					DC	-	a	l			
2 B	- 20	2 H			DC	A	a	-	3	3	-
					AC	C	k	-			
2 A	- 20	T 2			DC	A	-	a	3	3	-
					AC	C	-	k			
3 B	- 20	3 H			DC	A	A	-	2	4	4
					AC	C	C	-			
3 A	- 20	T 3			DC	A	-	A	2	4	4
					AC	C	-	C			
81 B	- 20	4 H			DC	F	a	-	3	3	-
					AC	H	k	-			
8 A	- 20	T 4			DC	F	-	a	3	3	-
					AC	H	-	k			









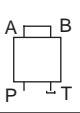
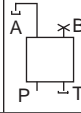
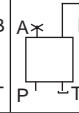
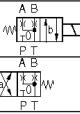
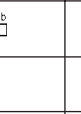
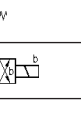

* max. zulässiger Betriebsdruck $p_{max} = 250$ bar; * max. operating pressure $p_{max} = 250$ bar; * press. di funzionamento max. $p_{max} = 250$ bar

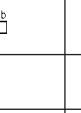
Wegeventil, NG 10
Directional control valve, size 5
Valvola distributrice, grandezza 5

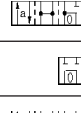
Baureihe J-KSO
Series J-KSO
Serie J-KSO

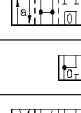
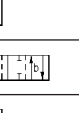
Ausführungsvarianten und Schaltzeichen (andere Varianten auf Anfrage)
Standard models and symbols (other variants on request)
Varianti d'esecuzione e simboli (altri modelli su richiesta)

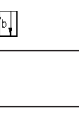
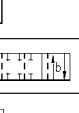
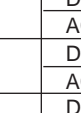
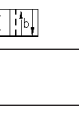
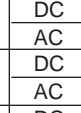
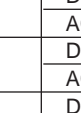
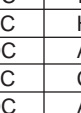
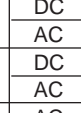
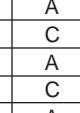
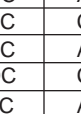
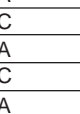
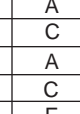
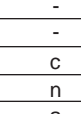
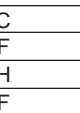
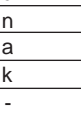
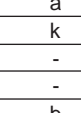
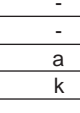
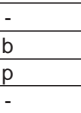
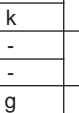
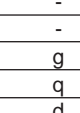
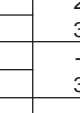
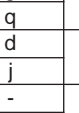
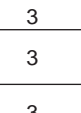
Tabelle 2 / Table 2 / Tabella 2

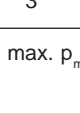
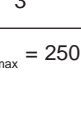
Kolbentyp / Kolbenstückstellung Spool type / Function Tipo di pistone / richiamo pistone	Ausführungskennzeichen Design-no. Numero del tipo	Sonderausführung Special type Esecuzione speciale	Sinnbild Symbol Simbolo	Schaltzeichen mit Übergangsstellung Symbol with transient response Simbolo con posizione transitoria	Magnetspannung Powersupply Tensione d'alimentazione	Max. Durchfluß L/min Max. flow rate L/min Portata massima L/min (Seite 7, page 7, pagina 7)			Δp-Q Kennlinie Δp-Q characteristic Curva caratteristica Δp-Q (Seite 7, page 7, pagina 7)		
									P->A P->B	B->T A->T	P->T
81 B	- 20	44 H			DC AC	F H	a k	- -	3 3	3 -	- -
8 A	- 20	T 44			DC AC	F H	- -	a k	3 3	3 -	- -
3 B	- 20	5 T			DC AC	A C	- -	c n	2 4	- 6	4 4
3 A	- 20	H 5			DC AC	A C	A C	- -	2 -	2 6	4 4
3 B	- 20	66 T	* 	* 	DC AC	G I	- -	h t	- -	7 7	7 7
3 A	- 20	H 66	* 	* 	DC AC	G I	h t	- -	5 -	7 7	7 7
9 B	- 20	7 H			DC AC	A C	f r	f r	2 -	3 -	- -
91 A	- 20	T 7			DC AC	A C	f r	f r	2 -	3 -	- -
2 B	- 20	8 H			DC AC	F H	a k	- -	3 3	3 -	- -
8 A	- 20	T 8			DC AC	F H	- -	a k	3 3	3 -	- -
9 B	- 20	9 H			DC AC	A C	g q	- -	2 -	3 -	- -
2 A	- 20	T 9			DC AC	A C	g q	b p	2 3	- 3	- -
3 B	- 20	51 T			AC DC	A C	- -	A C	- 2	6 2	4 4
3 A	- 20	H 51			AC DC	A C	c n	- -	- 2	6 2	4 4
81 B	- 20	81 H			AC DC	F H	a k	- -	3 3	3 -	- -
2 A	- 20	T 81			AC DC	F H	- -	a k	3 3	3 -	- -
2 B	- 20	91 H			AC DC	A C	b p	- -	2 3	3 -	- -
91 A	- 20	T 91			AC DC	A C	- -	g q	- 3	3 -	- -
2 B	- 20	T 2			AC DC	B D	- -	d j	3 -	3 -	- -
2 A	- 20	2 H			DC AC	B D	d i	- -	3 3	3 -	- -

* max. zulässiger Betriebsdruck $p_{max} = 250$ bar; * max. operating pressure $p_{max} = 250$ bar; * press. di funzionamento max. $p_{max} = 250$ bar

Tabelle 2 / Table 2 / Tabella 2

Hinweis:

- Die max. Durchflußstromwerte wurden ermittelt bei betriebswarmen Magneten und 10% Unterspannung
- Bei AC-Spannung liegt eine Netz-Frequenz von 60 Hz zugrunde
- Der max. Durchflußstromwert ist zulässig für jeden zu durchströmenden Kanal

Note:

- Max. flow rate is based on figures measured with warm solenoids and 10% undervoltage
- Measured at 60 Hz and in case of AC
- Max. flow rate is allowable flow rate of each port

Nota:

- La portata massima è stata determinata con bobine calde e 10 % sottotensione
- Misurazione con tensione alternata 60 Hz
- Portata massima ammissibile per ciascun canale di portata

Wegeventil, NG 10
Directional control valve, size 5
Valvola distributrice, grandezza 5

Baureihe J-KSO
Series J-KSO
Serie J-KSO

Kennlinien
Characteristics
Curve caratteristiche

ermittelt bei $v = 32 \text{ mm}^2/\text{s}$ · determ. at $v = 32 \text{ mm}^2/\text{s}$ · determinate con $v = 32 \text{ mm}^2/\text{s}$

Max. Durchfluß · Max. flow rate · Portata massima



Bild 2
Fig. 2



Bild 3
Fig. 3

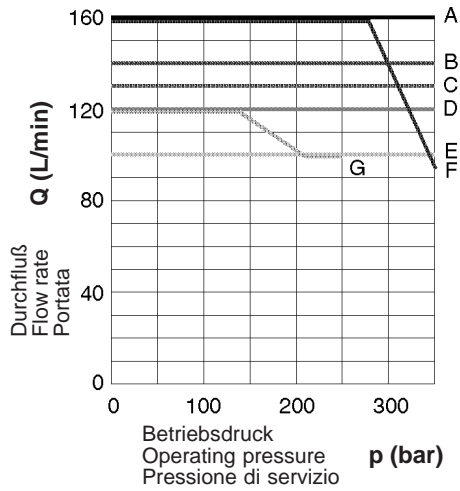

Bild 4
Fig. 4

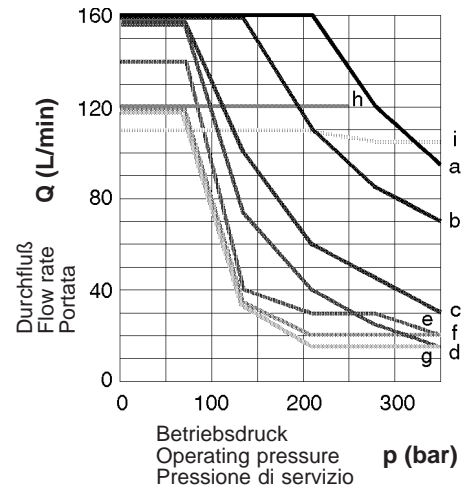

Bild 5
Fig. 5

Druckabfall · Pressure drop · Caduta di pressione

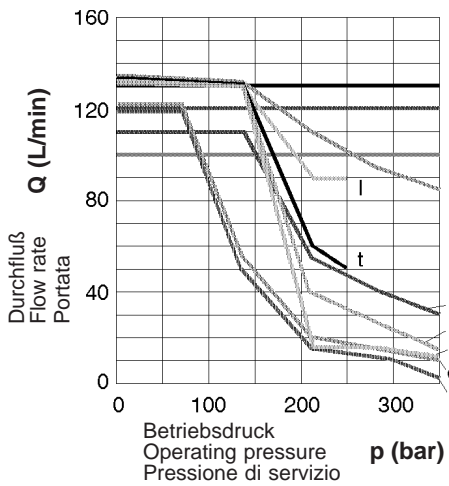

Bild 6
Fig. 6

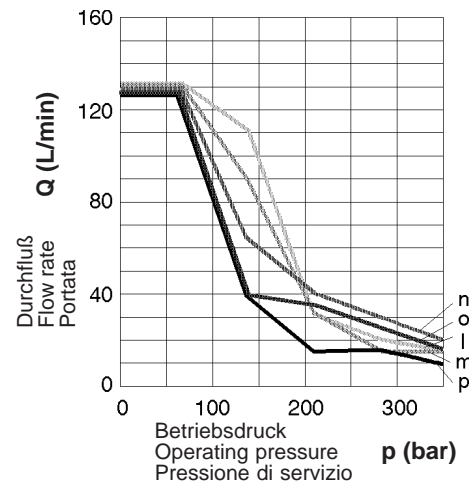
Wegeventil, NG 10
Directional control valve, size 5
Valvola distributrice, grandezza 5

Baureihe J-KSO
Series J-KSO
Serie J-KSO

Kennlinie Q - Δp (Einsteckdrossel)
Characteristic Q - Δp (Fixed throttle)
Curva caratteristica Q - Δp (diaframma inserito)

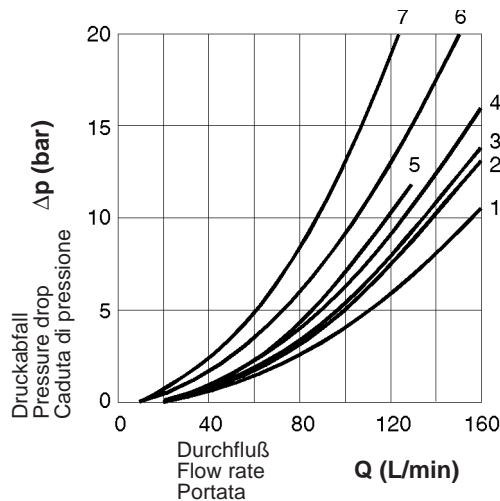

Bild 7
Fig. 7

Druckabfall
 Pressure drop $\Delta p(\text{bar})$
 Caduta di pressione

Bezeichnung Designation Designazione	(Bild 7, Fig. 7) $\varnothing A$	Bestell-Nr. Part.-no. N° ordinaz.
Einsteckdrossel	0,8 mm	744 292
	1,0 mm	744 300
Fixed throttle	1,2 mm	744 318
Diaframma inserito	1,4 mm	744 326
	2,0 mm	6045355

Weitere Ausführungen auf Anfrage
 Other variants on request
 Altri modelli su richiesta

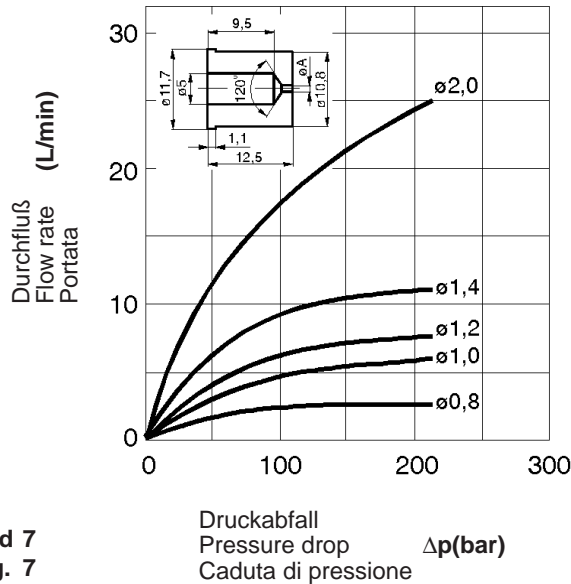
Tabelle 3 / Table 3 / Tabella 3

Hinweis:

Die Durchflußkennwerte für den jeweiligen Einsteckdrossel - Durchmesser sind der Q- Δp Kennlinie, Bild 6 zu entnehmen

Die Einsteckdrossel kann im P-, A- und B-Kanal verwendet werden.

Note:

Flow characteristic of the specific fixed throttle diameter can be seen from the Q- Δp characteristic fig. 6.

The fixed throttle can be used in the P, A and B channel.

Nota:

Le caratteristiche per il diametro del corrispondente diaframma inserito possono essere dedotte dalla curva caratteristica Q- Δp , fig. 6.

Il diaframma può essere utilizzato nei canali P, A e B.

Wegeventil, NG 10
Directional control valve, size 5
Valvola distributrice, grandezza 5

Baureihe J-KSO
Series J-KSO
Serie J-KSO

Geräteabmessungen mit Gleichstrommagnet
Installation dimensions with direct-current solenoid
Dimensioni dell'apparecchio con bobina per corrente continua



Bild 8
Fig. 8



Bei Montage des Ventils ohne Anschlußplatte ist folgende Oberflächengüte des Gegenstückes erforderlich:

When assembling the valve without subplate, the following surface quality of the counterpart is required:

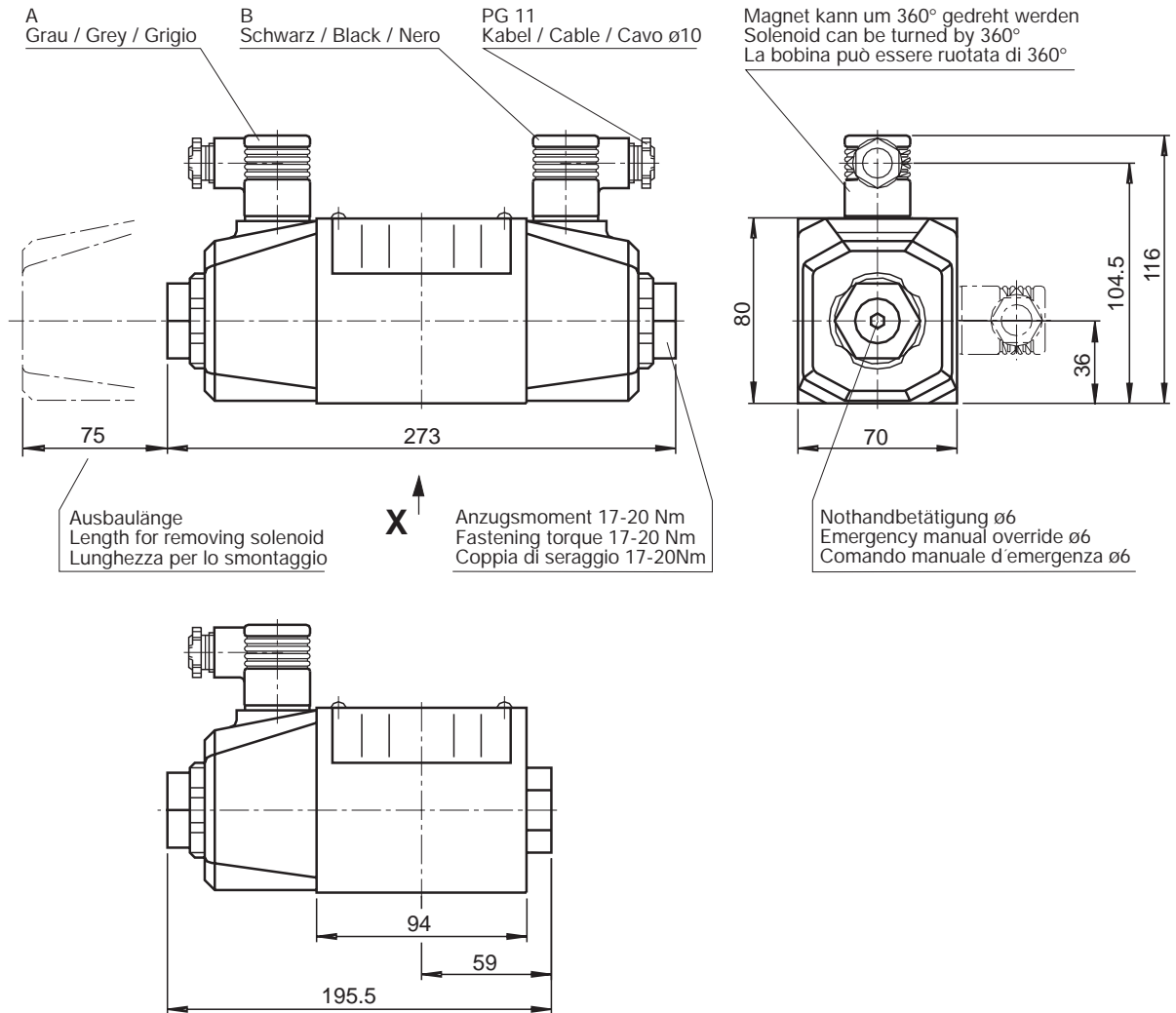
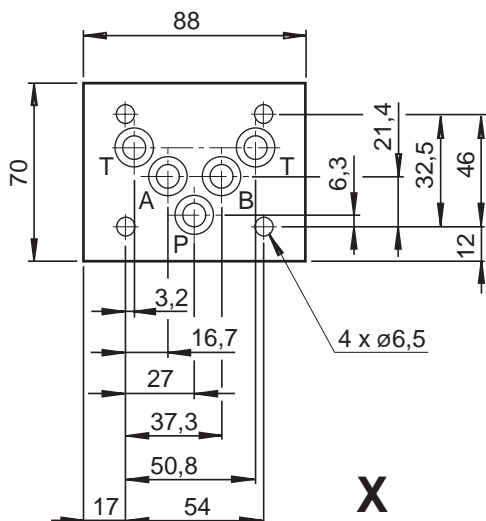
Per il montaggio della valvola distributrice senza piastra di raccordo è necessaria la qualità della superficie del controprezzo indicata a fianco:

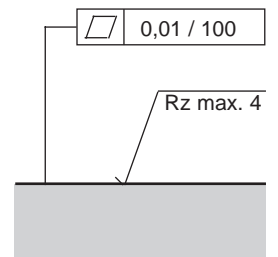

Wegeventil, NG 10
Directional control valve, size 5
Valvola distributrice, grandezza 5

Baureihe J-KSO
Series J-KSO
Serie J-KSO

Geräteabmessungen mit Wechselstrommagnet
Installation dimensions with alternating-current solenoid
Dimensioni dell'apparecchio con bobina per corrente alternata



Bild 9
Fig. 9

Befestigungsschrauben - Fixing bolts - Viti di fissaggio

Zylinderschraube
M 6 x 35 - DIN 912 - 10.9
Anzugsmoment 11 Nm bis 15 Nm
Gehört nicht zum Lieferumfang
Best.-Nr.: 508994

Cylinder screw
M 6 x 35 - DIN 912 - 10.9
Tightening torque 11 Nm to 15 Nm
Not included in delivery scope
Part.-no.: 508994

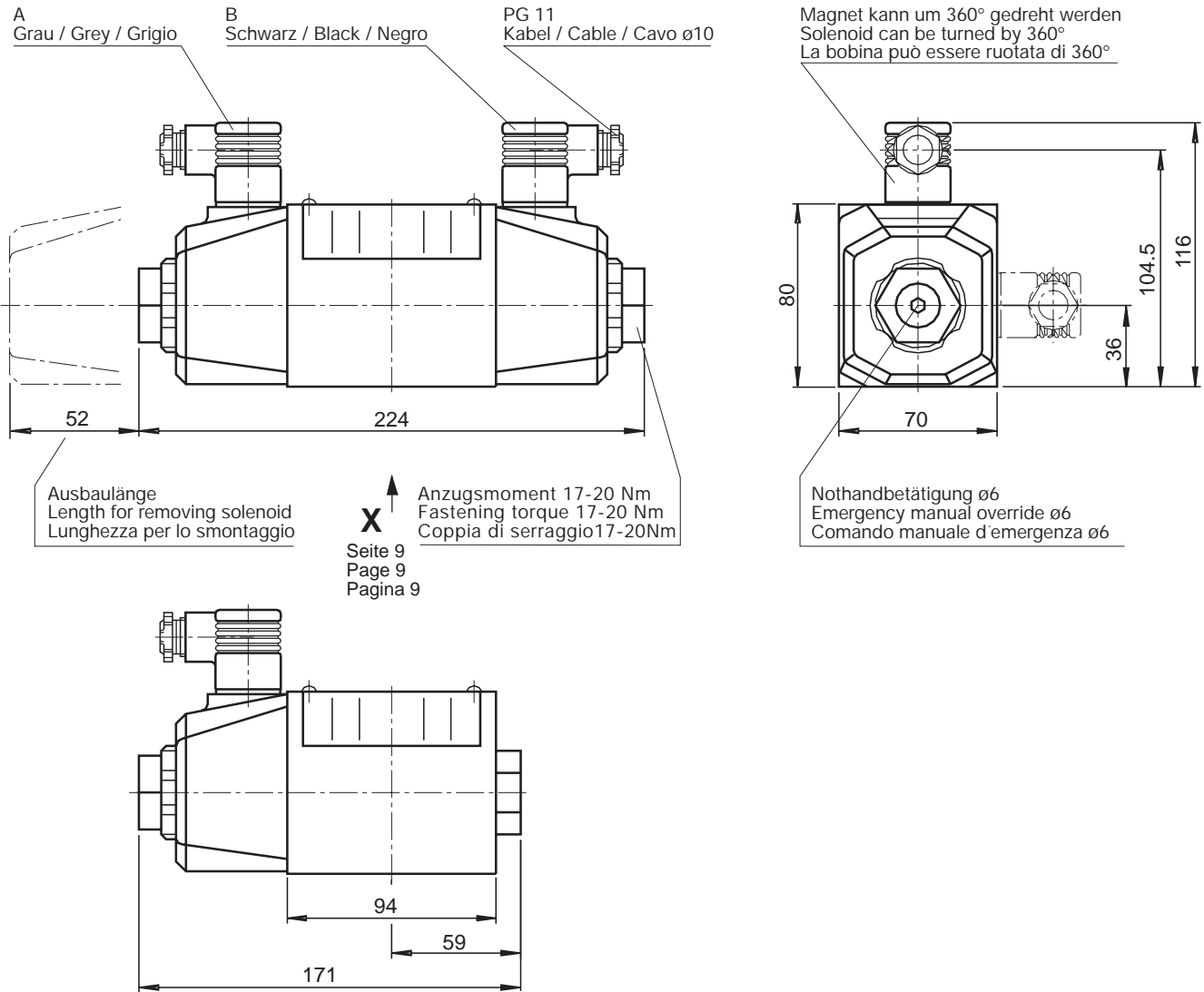
Vite a testa cilindrica
M 6 x 35 - DIN 912 - 10.9
Coppia di serraggio da 11 Nm a 15 Nm
Non compresa nell'estensione della fornitura
N° ordinaz. : 508994

Wegeventil, NG 10
Directional control valve, size 5
Valvola distributrice, grandezza 5

Baureihe J-KSO
Series J-KSO
Serie J-KSO

Anschlußplatten · Connection plates · Piastre di raccordo

Anschlußplatte G 1/2, M18 x 1,5 · Connection plate G 1/2, M18 x 1,5 · Piastra di raccordo G 1/2, M18 x 1,5



Bild 10
Fig. 10

Anschlußplatte G 3/4 · Connection plate G 3/4 · Piastra di raccordo G 3/4

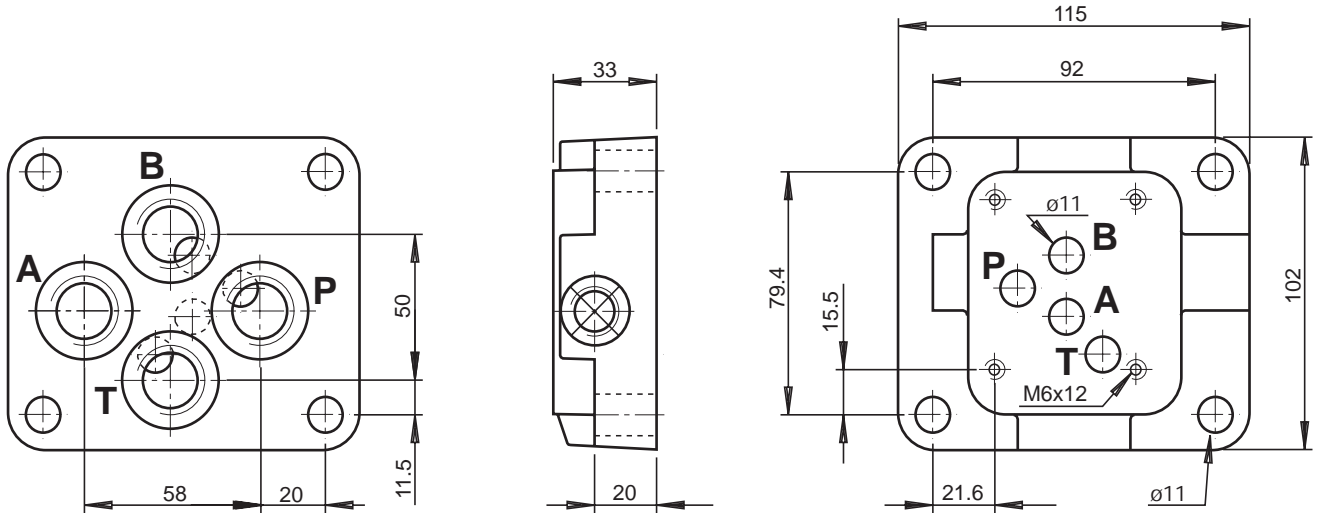

Bild 11
Fig. 11

Anschlußgewinde Threaded con. Raccordo filettato	Best.-Nr. Part.-no. N° ordinaz.
G 1/2	6000624
G 3/4	6000632
M18 x 1,5	744011

Anschlußplatten mit anderen Anschlußgewinden auf Anfrage
 Connection plates with other threads on inquiry
 Piastre di raccordo con altre filettature su richiesta

Tabelle 4 / Table 4 / Tabella 4

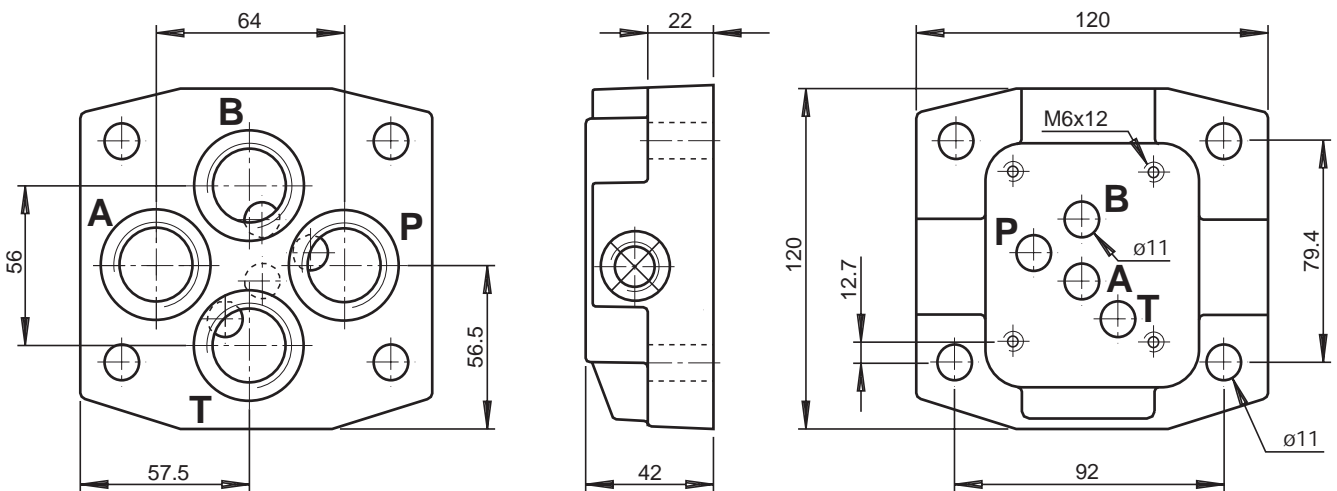
Lieferprogramm

SAUER BIBUS liefert ein komplettes Programm an Hydraulikkomponenten, von Regelpumpen im offenen Kreislauf über Ventile bis hin zu kompletten hydrostatischen Antriebssystemen und Steuerungen für den Stationär- und Mobilmarkt.

SAUER BIBUS bietet Kunden und zukünftigen Kunden erfahrungsorientierte Ingenieurleistung von der Projektstudie bis zu Serienfertigung. Wir beraten Sie und lassen Sie von unseren Erfahrungen aus vielen Anwendungsfällen profitieren.

Sales Program





SAUER BIBUS furnishes a complete program of hydraulic components from valves and open circuit variable displacement pumps right up to complete hydrostatic drive systems and controls for stationary and mobile market.

SAUER BIBUS offers present and future customers engineering services based on sound experience, from project studies to serial production. We shall be glad to advise you and enable you to profit from our store of experience gained from countless applications.

Programma di vendita

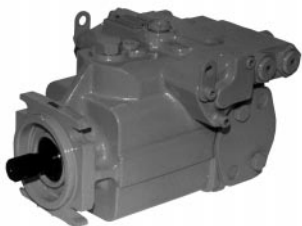
La **SAUER BIBUS** è in grado di fornire un programma completo di componenti idraulici, dalle valvole e pompe in circuito aperto a cilindrata variabile fino ai controlli e ai sistemi completi per l'azionamento idrostatico per i mercati del Mobile e dell' Industriale.

La **SAUER BIBUS** offre ai clienti attuali e futuri un servizio tecnico basato su una solida esperienza, dalla progettazione alla produzione di serie. Saremo lieti di consigliarvi e di farvi trarre profitto dal nostro bagaglio di esperienza acquisito in innumerevoli applicazioni.

 <p>Axialkolben-Verstellpumpen J-V / J-HV Variable Displacement Axial Piston Pumps J-V / J-HV Pompe variabili a pistoni assiali J-V / J-HV</p>	 <p>Axialkolben-Verstellpumpen J-VZ Variable Displacement Axial Piston Pumps J-VZ Pompe variabili a pistoni assiali J-VZ</p>	 <p>Rotorpumpen J-RP Rotor Pumps J-RP Roto Pompe J-RP</p>
 <p>Wegeventile Directional Control Valves Elettrovalvole</p>	 <p>Zwischenplattenventile Multi-Stack-Valves Valvole modulari</p>	 <p>Proportionalventile Proportional Control Valves Valvole proporzionali</p>

SAUER BIBUS Service weltweit ...

Der weltweite Fertigungs- und Entwicklungsverbund SAUER SUNDSTRAND für Europa, Afrika und den Nahen Osten. SUNDSTRAND SAUER in den USA für die amerikanische Hemisphäre und DAIKIN in Japan für den ostasiatischen Raum, ermöglicht es SAUER BIBUS, in fast allen Ländern der Welt Service zu bieten.

SAUER BIBUS Service worldwide ...

Thanks to the worldwide manufacturing and development cooperation between SAUER SUNDSTRAND for Europe, Africa and the Near East, SUNDSTRAND SAUER in the US for the American hemisphere and DAIKIN in Japan for the Far East. SAUER BIBUS is able to offer service facilities in almost every country in the world.

Assistenza SAUER BIBUS nel mondo ...

Grazie agli stabilimenti produttivi sparsi nel mondo e alla cooperazione nella ricerca tra SAUER SUNDSTRAND per l'Europa, Africa e Medio Oriente, SUNDSTRAND SAUER negli USA per l'emisfero Americano e DAIKIN in Giappone per l'estremo oriente, la SAUER BIBUS è in grado di offrire un servizio assistenza in quasi tutti i paesi del mondo.

Druckfehler, Irrtümer und Technische Änderungen vorbehalten

Misprint, errors and contents subject to technical changes

Questo testo è valido salvo errori di stampa e sviste ed è soggetto a cambiamenti tecnici.

SAUER  **BIBUS**

Sauer Bibus GmbH
Im Riedle 10
D-89278 Nersingen
Telefon: (07308) 9660-0
Telefax: (07308) 9660-10
e-mail SAUER_BIBUS@T-ONLINE.DE

SAUER  **SUNDSTRAND**

Via Bonazzi 19/21
40013 Castel Maggiore - BO
Tel.: (051) 70.17.45 - 70.16.89
Telefax: (051) 701386
Telex: 511287 Turbo I